

1509348COM 3 Drawer Dresser

Date of Purchase ___ / ___ / ___

Lot Number:

B341509348COM2

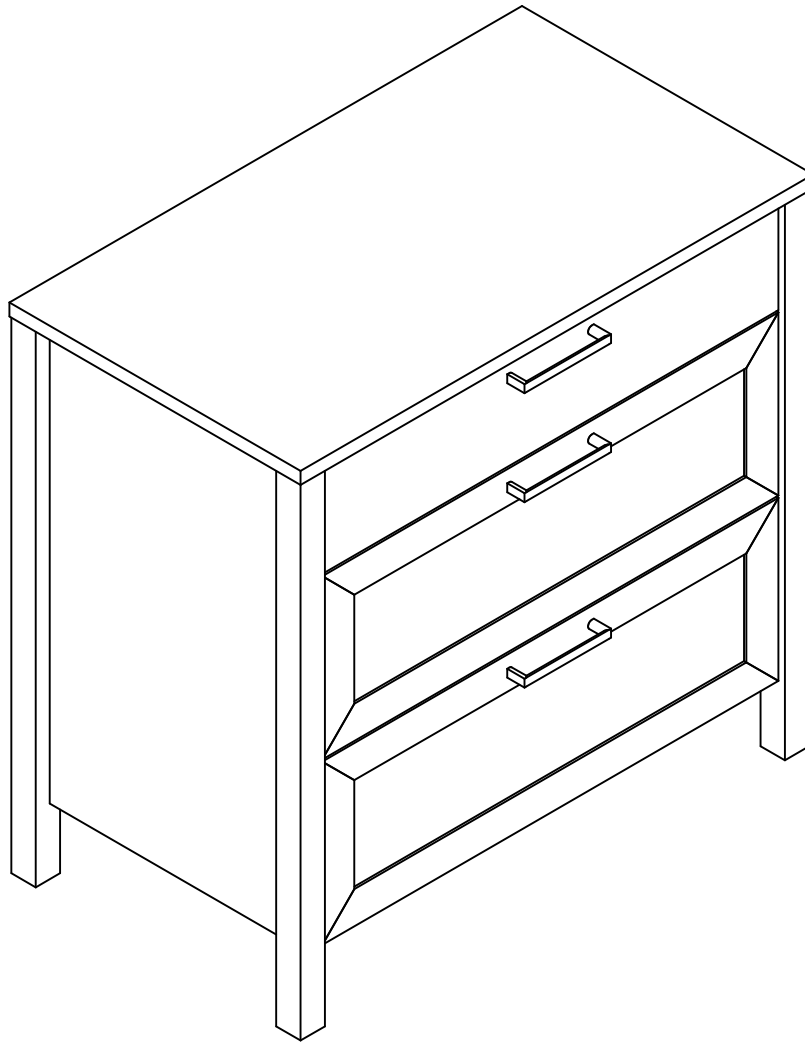

Do Not Return This Product!

Contact our customer service team for help first.

Call: 1-800-489-3351 (toll free)

Monday-Friday 9am - 5pm CST

Visit: www.ameriwoodhome.com

THIS INSTRUCTION BOOKLET CONTAINS **IMPORTANT** SAFETY INFORMATION. PLEASE READ AND KEEP FOR FUTURE REFERENCE.

Keep your home and family safe with the wall anchor kit that is included with the product.

Serious or fatal crushing injuries can occur from tipping furniture.

WARNING: Manufacturer assumes no liability for improper installation or excessive loads placed on screws or bracket. This wall anchor is not a substitute for proper adult supervision.

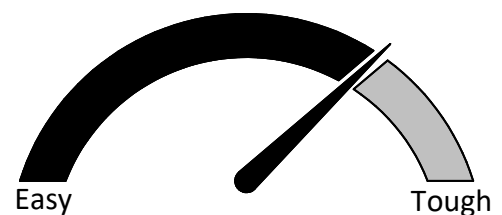

Assembly Difficulty Meter

Contact Us!

Do NOT return this product!

Contact our friendly customer service team first for help.

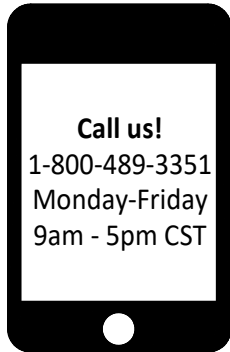

Visit ameriwoodhome.com to view the limited warranty valid in the U.S. and Canada.

Assembly Tips



Helpful Hints

PEOPLE NEEDED FOR ASSEMBLY: 1-2

- Open your item in the area you plan to keep it to avoid excessive heavy lifting.
- Identify, sort and count the parts before attempting assembly.
- Compression dowels are lightly tapped in with a hammer.
- Slides are labeled with a **R** (right) and **L** (left) for proper placement.
- Make sure to always face the point on the top of the Cam Lock towards the outer edge.
- Use all the nails provided for the back panel and spread them out equally.
- Back panel must be used to make sure your unit is sturdy.
- Do NOT use harsh chemicals or abrasive cleaners on this item.
- Never push, pull, or drag your furniture.



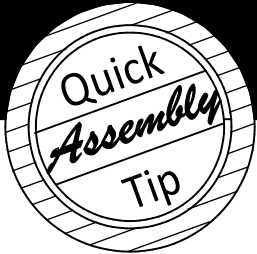

Before You Start

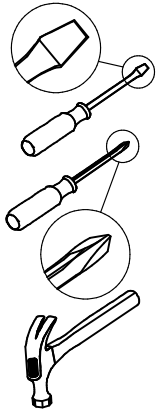

- ✓ Read through each step carefully and follow the proper order
- ✓ Separate and count all your parts and hardware
Parts are labeled on the surface or edge of the part
- ✓ Give yourself enough room for the assembly process
- ✓ Have the following tools: Flat Head Screwdriver, #2 Phillips Head Screwdriver and Hammer
- ✓ Caution: If using a power drill or power screwdriver for screwing, please be aware to slow down and stop when screw is tight. Failure to do so may result in stripping the screw.

Cam Lock Fastening System

This Cam Lock Fastening System will be used throughout the assembly process.

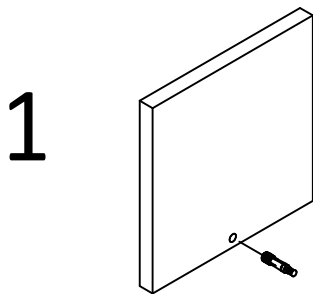

Press CAM BOLT into hole.

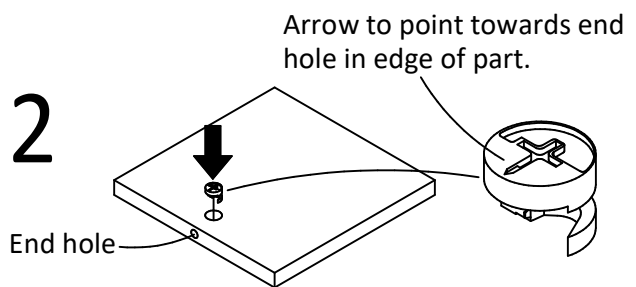

Press CAM LOCK into hole.

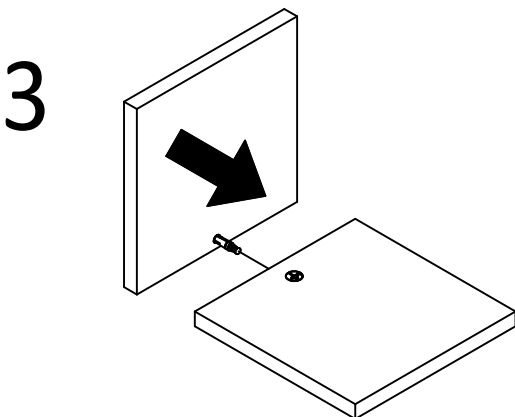

Press parts together so CAM BOLT inserts into edge hole.

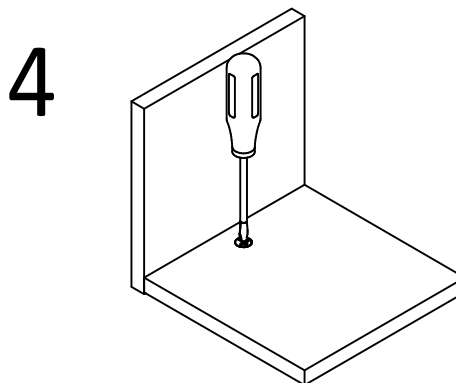

Using a screwdriver, turn the CAM LOCK clockwise to lock the CAM LOCK and CAM BOLT into their holes and fastening parts together.

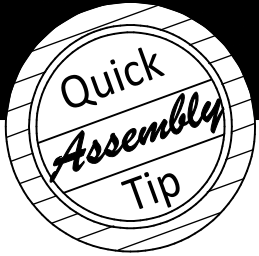

Before You Start

Please Note:
You may need to lightly tap the wood dowels to insert into the holes during your assembly process.

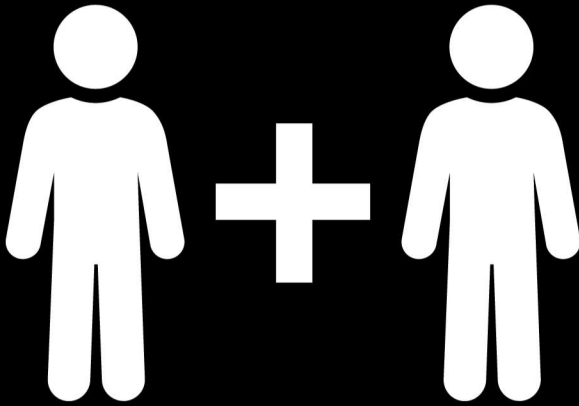
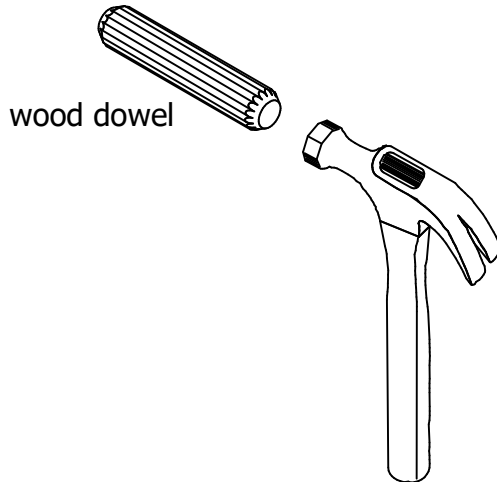

2 PEOPLE NEEDED FOR ASSEMBLY

**2 PERSONAS NECESITADAS
PARA LA ASAMBLEA**

**2 PERSONNES NÉCESSAIRES
POUR L'ASSEMBLAGE**

CAUTION: Failure to use 2 people for assembly could result in unit damage or personal injury.

PRECAUCIÓN: Si no se utilizan 2 personas para el ensamblaje, se pueden producir daños en la unidad o lesiones personales.

ATTENTION: Échec d'utiliser 2 personnes pour l'assemblage peut causer du dommage au meuble ou causer des blessures.

Board Identification

Not actual size

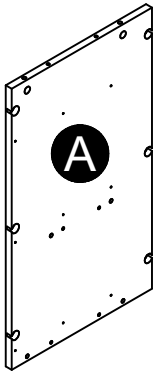

Left Panel
31509348010

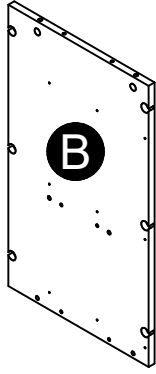

Right Panel
31509348020

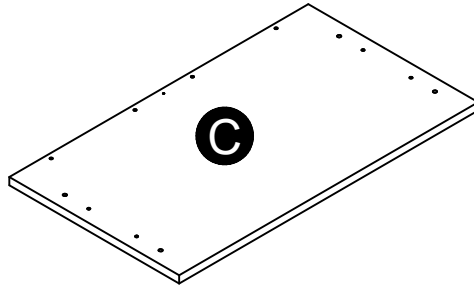

Top
31509348031

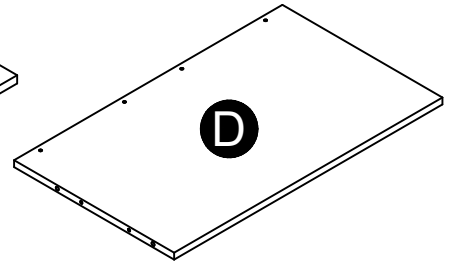

Bottom
31509348041

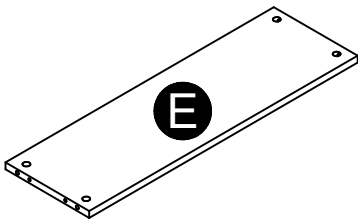

Support
31509000050

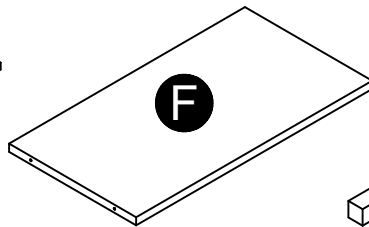

Back (x2)
31509000061

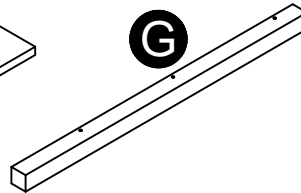

Left Front Leg
31509348070

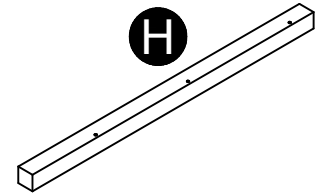

Right Front Leg
31509348080

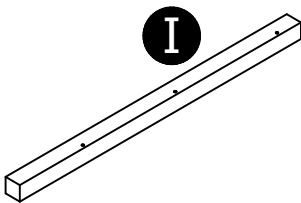

Left Rear Leg
31509348090

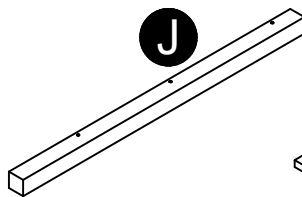

Right Rear Leg
31509348100

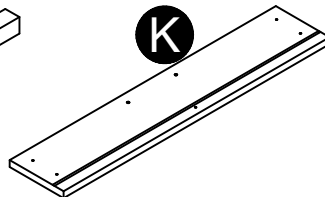

Upper Drawer Front
31509348110

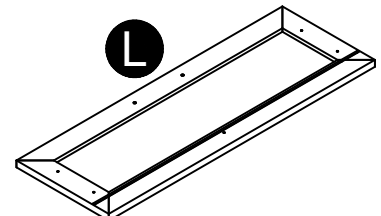

Drawer Front
31509348120

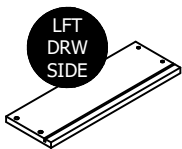

Left Drawer Side
39991120346410L

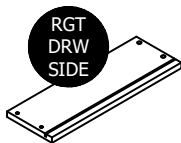

Right Drawer Side
39991120346410R

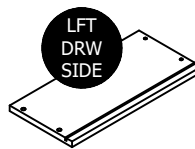

Left Drawer Side (x2)
39991167346410L



Right Drawer Side (x2)
39991167346410R

Board Identification

Not actual size

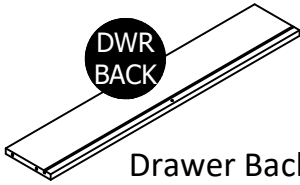

Drawer Back
39991120066618B

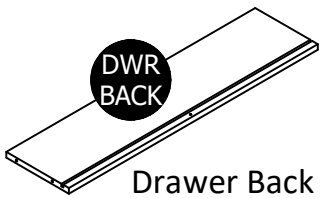

Drawer Back (x2)
39991167066618B

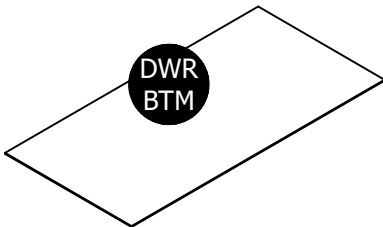

Drawer Bottom (x3)
39991338067710D

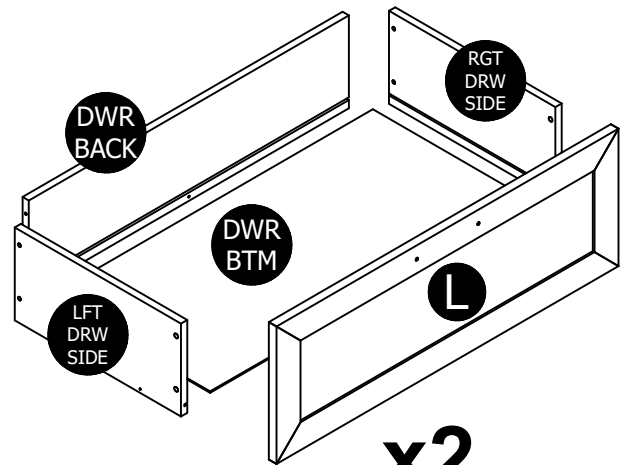
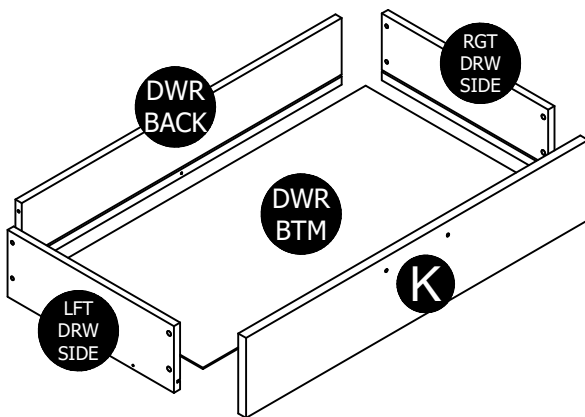
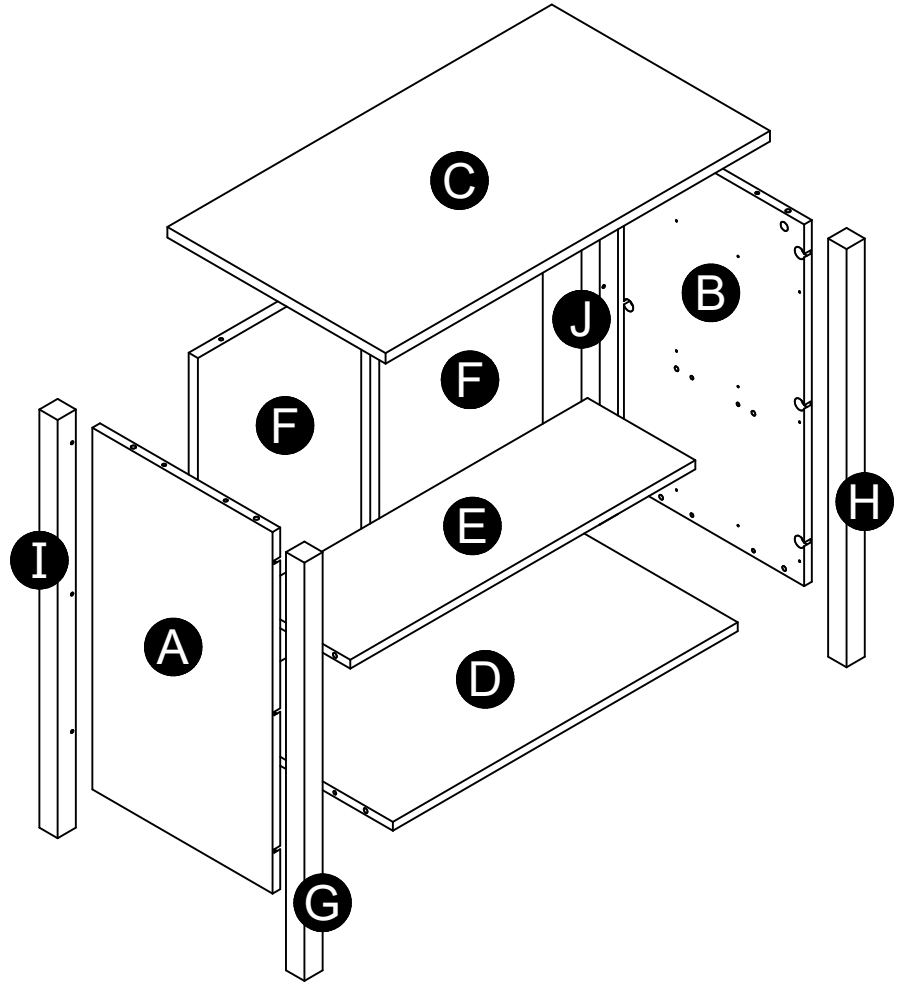

x2

Part List

Actual Size

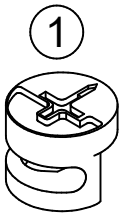

1

(x12)
#A22700
cam lock

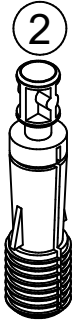

2

(x12)
#A22710
cam bolt



3

(x16)
#A21670
wood dowel

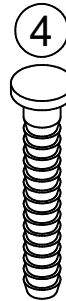

4

(x12)
#A21975
drive fastener



5

(x30)
#A12120
#8 x 7/16" screw



6

(x12)
#A22910
connector bolt

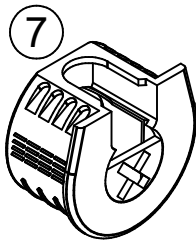

7

(x12)
#A22920
connector



8

(x30)
#A11080
#6 x 7/16" screw



9

(x6)
#A17400
8-32 x 7/8" truss

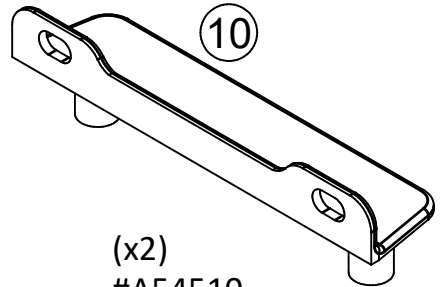

10

(x2)
#A54510
drawer bracket

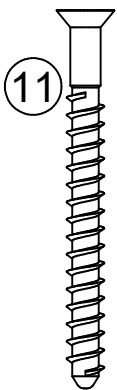

11

(x4)
#A23030
confirmat screw

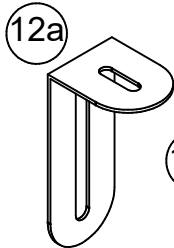

12a



12b



12c



12d

12

(x1)
#A84050
safety bracket kit
(not to size)

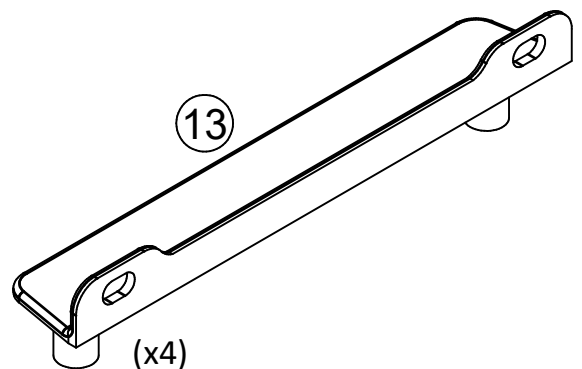

13

(x4)
#A54520
drawer bracket

Part List

Not Actual Size



Left Cabinet Member



Right Cabinet Member

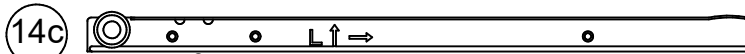

Left Drawer Member

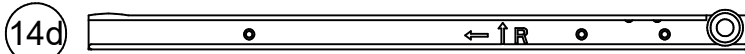

Right Drawer Member

(x3)
14 #A56770
drawer slide pkg.

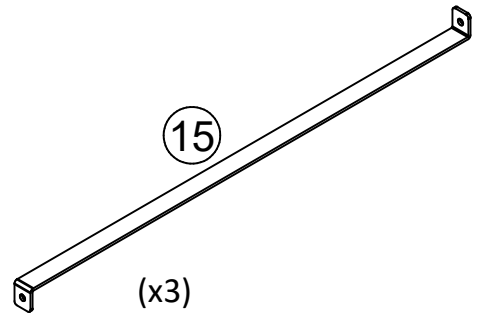

(x3)
#A54900
drawer brace

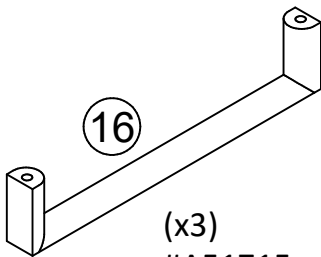

(x3)
#A51715
handle

STEP 1

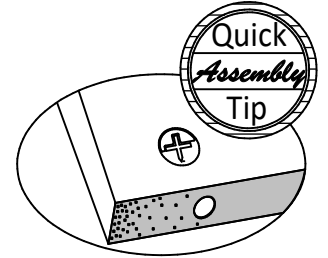
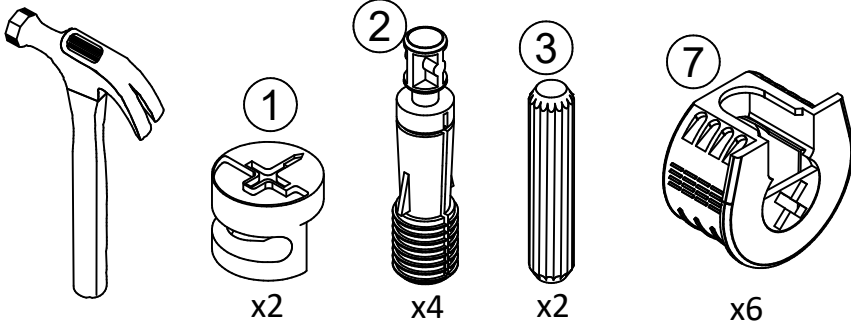

Proper orientation of CAM LOCK

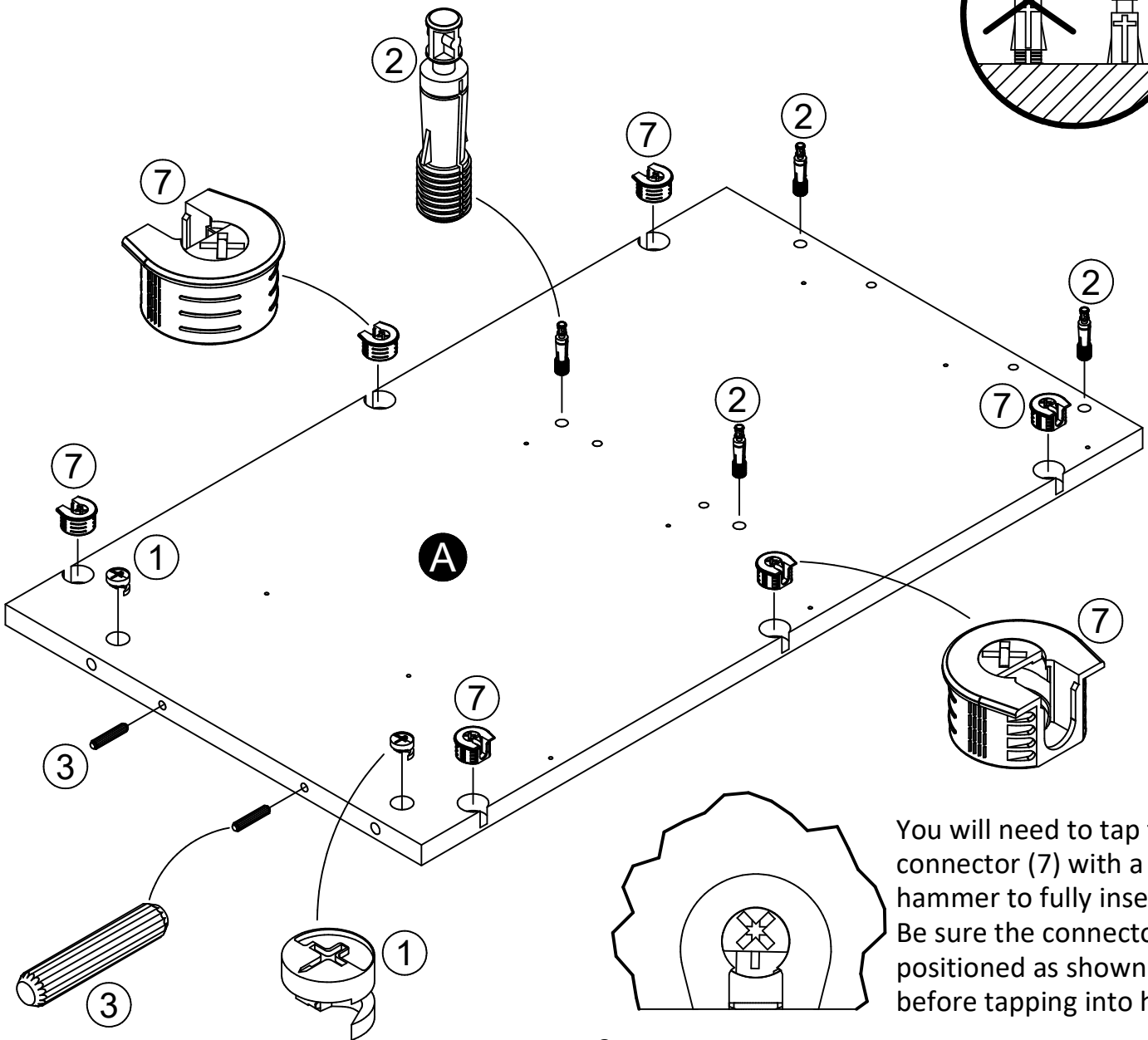
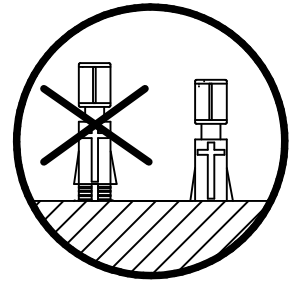

You will need to tap the connector (7) with a hammer to fully insert. Be sure the connector is positioned as shown before tapping into hole.

STEP 2

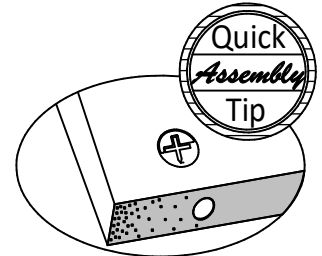
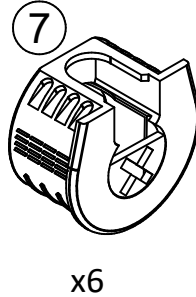
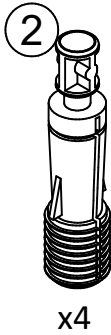
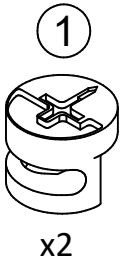
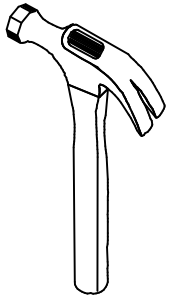

Proper orientation of CAM LOCK

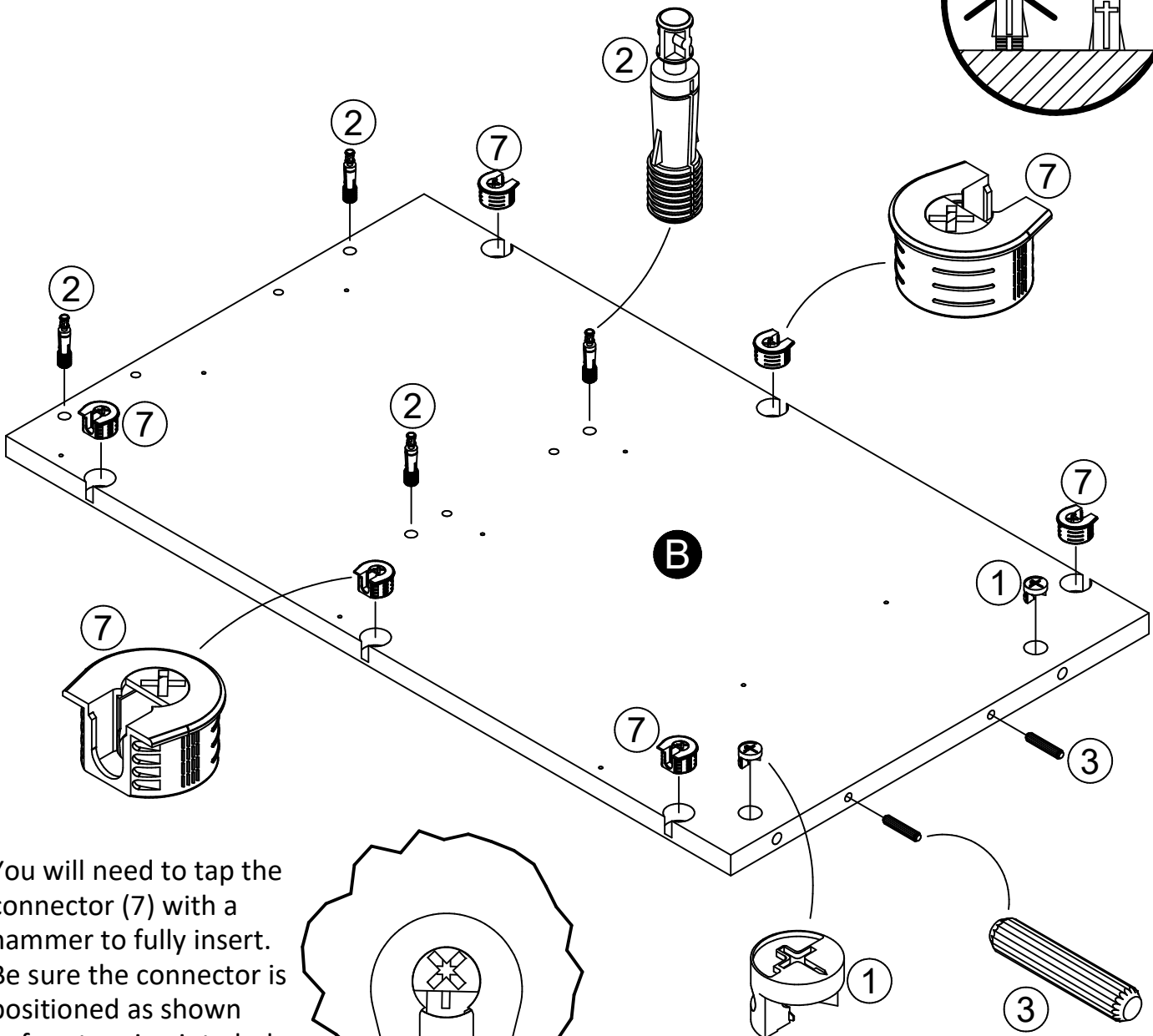
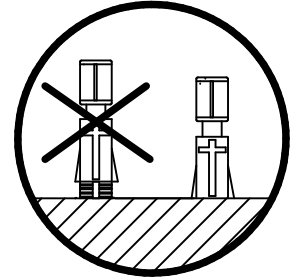

You will need to tap the connector (7) with a hammer to fully insert. Be sure the connector is positioned as shown before tapping into hole.

STEP 3

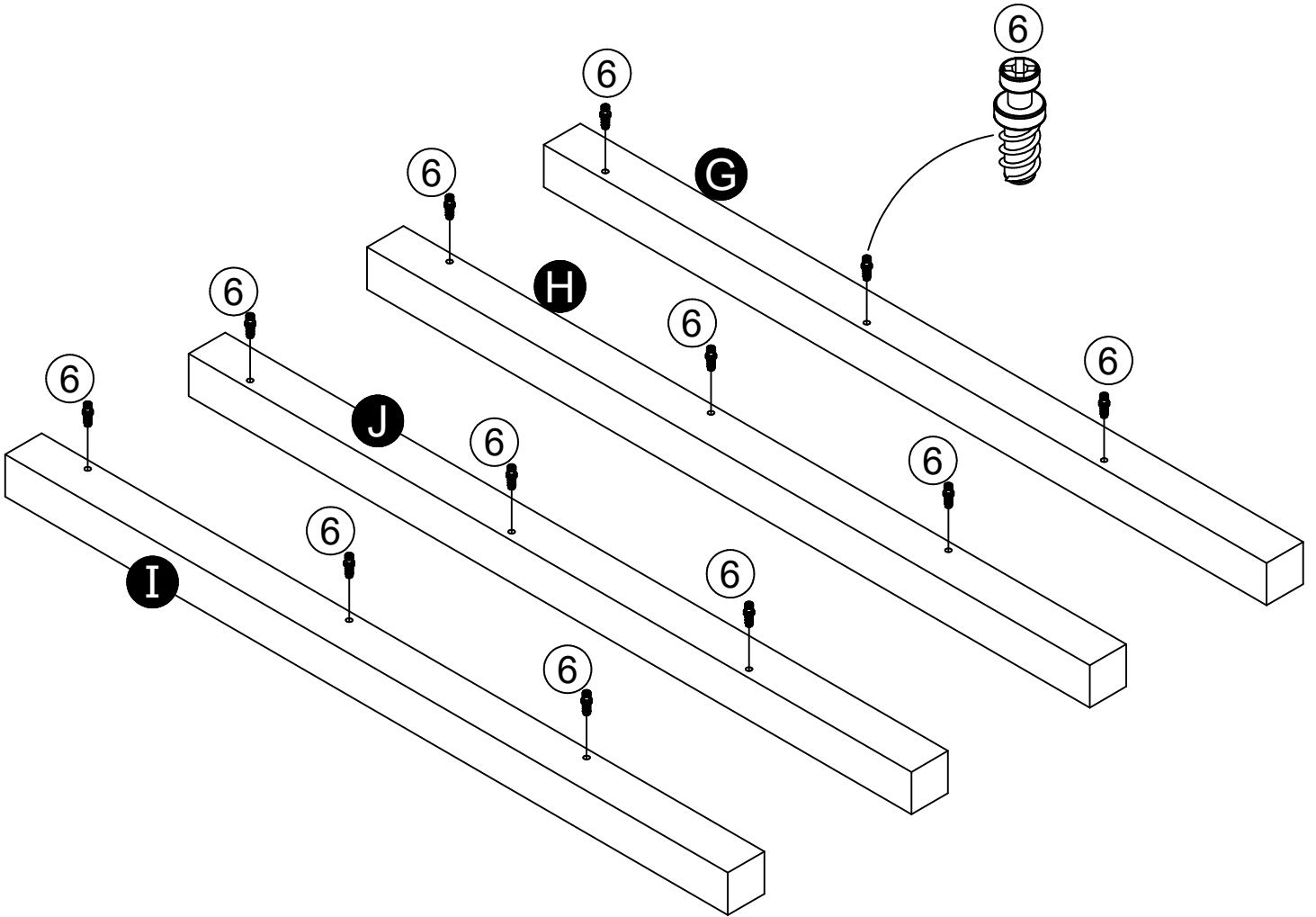
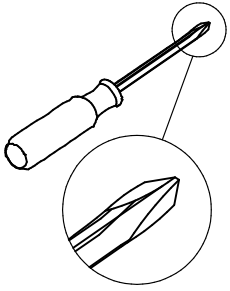

STEP 4

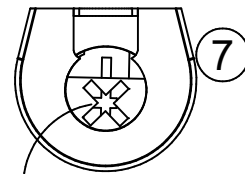
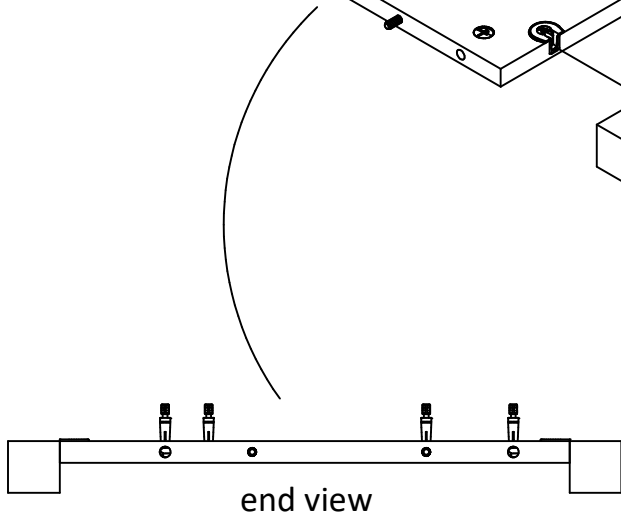
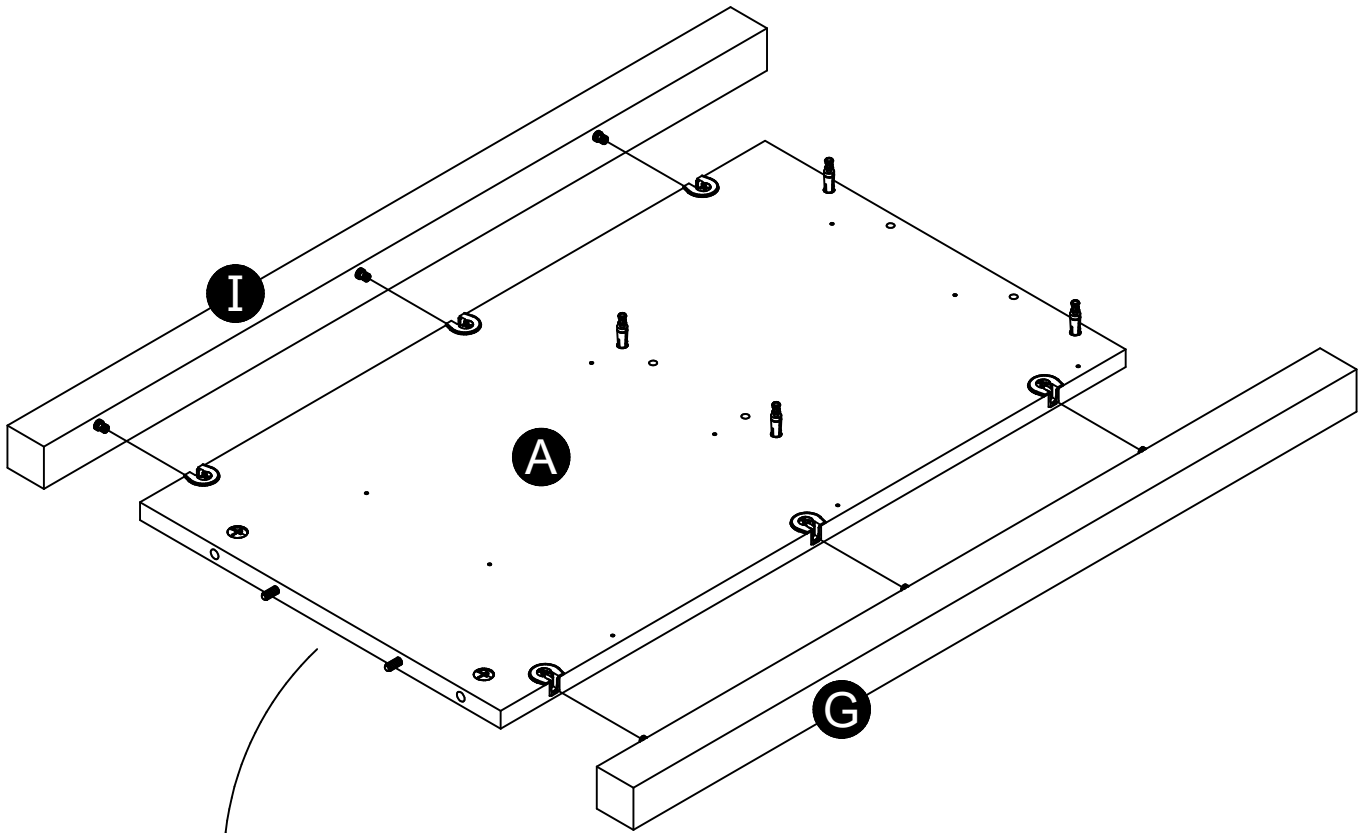
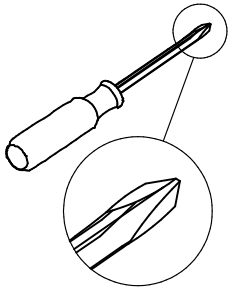

Turn clockwise to lock in place.

STEP 5

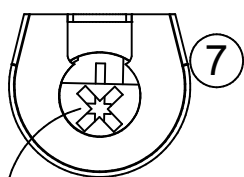
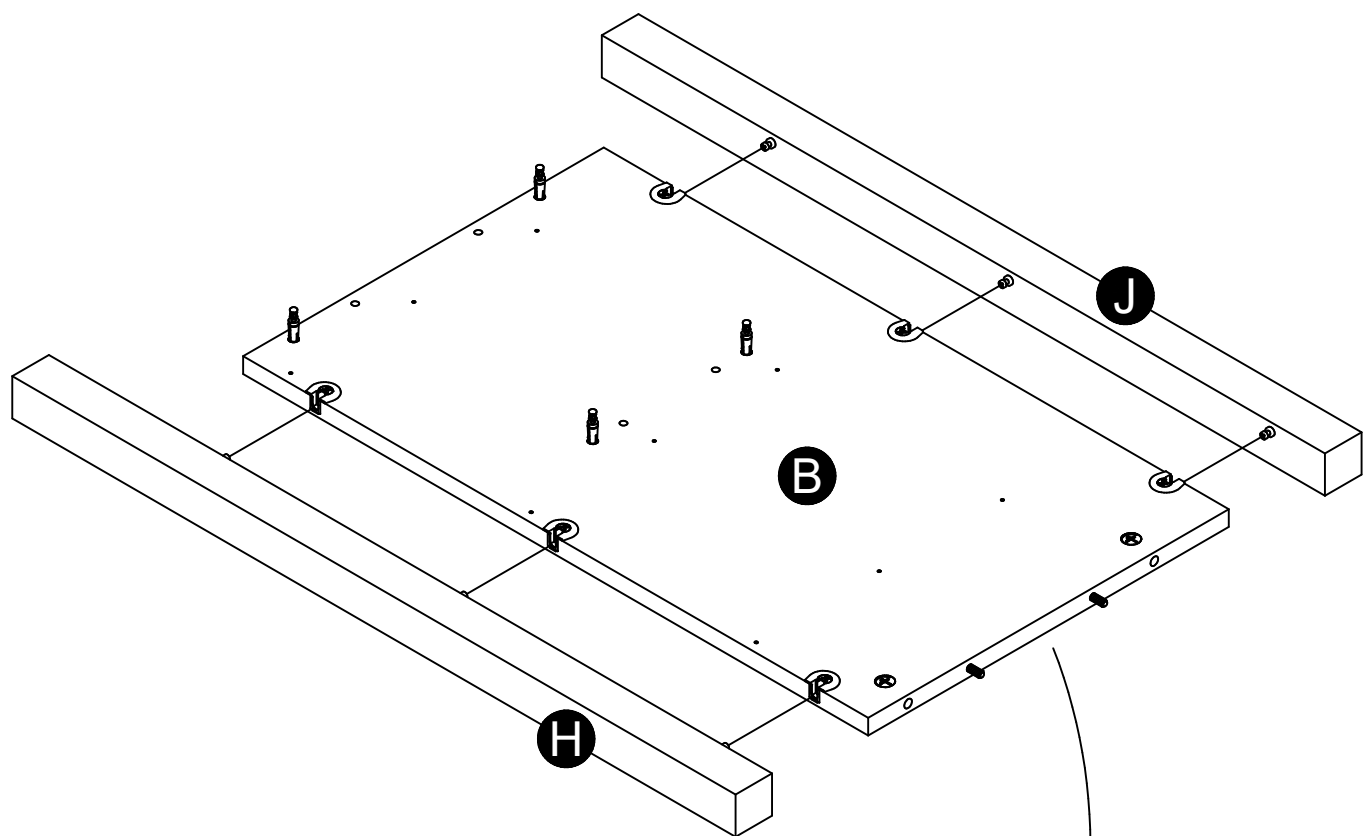
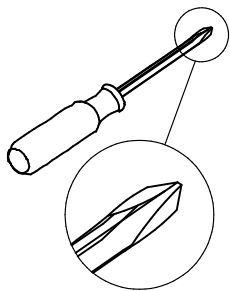

Turn clockwise to lock in place.

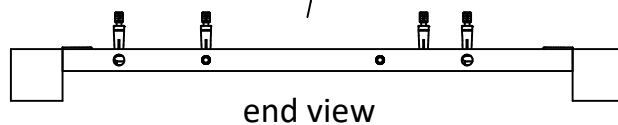

STEP 6

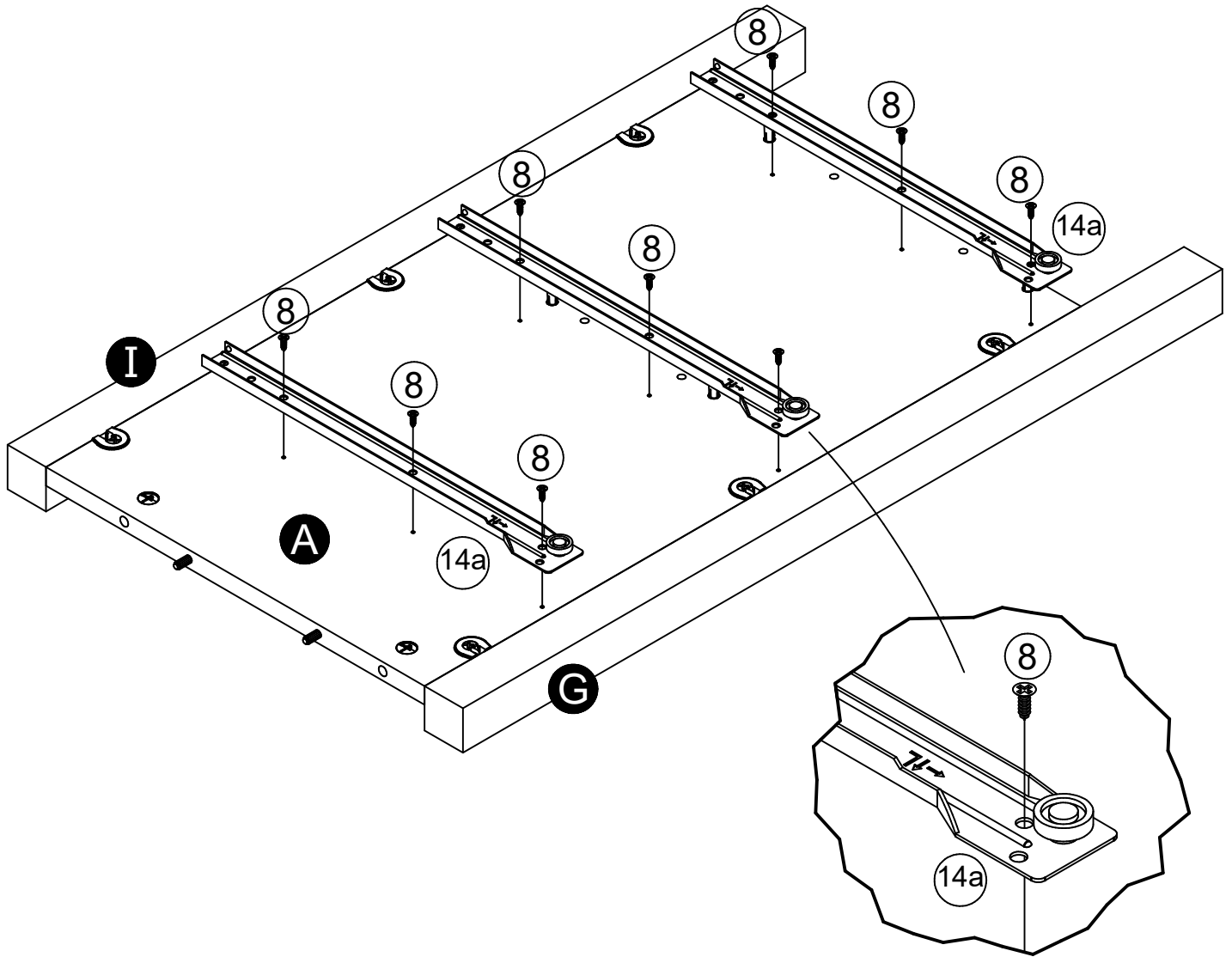
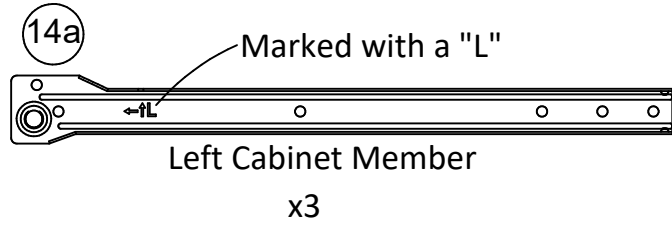
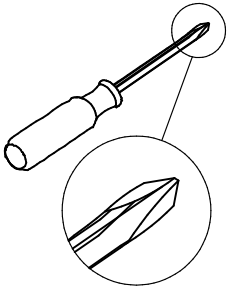

STEP 7

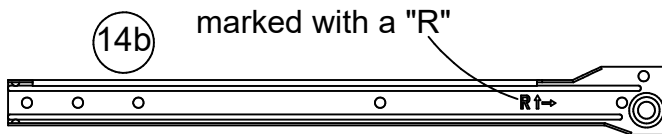
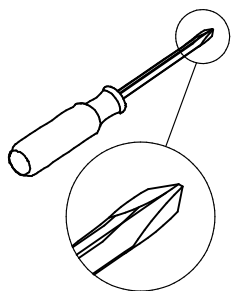

Right Cabinet Member
x3

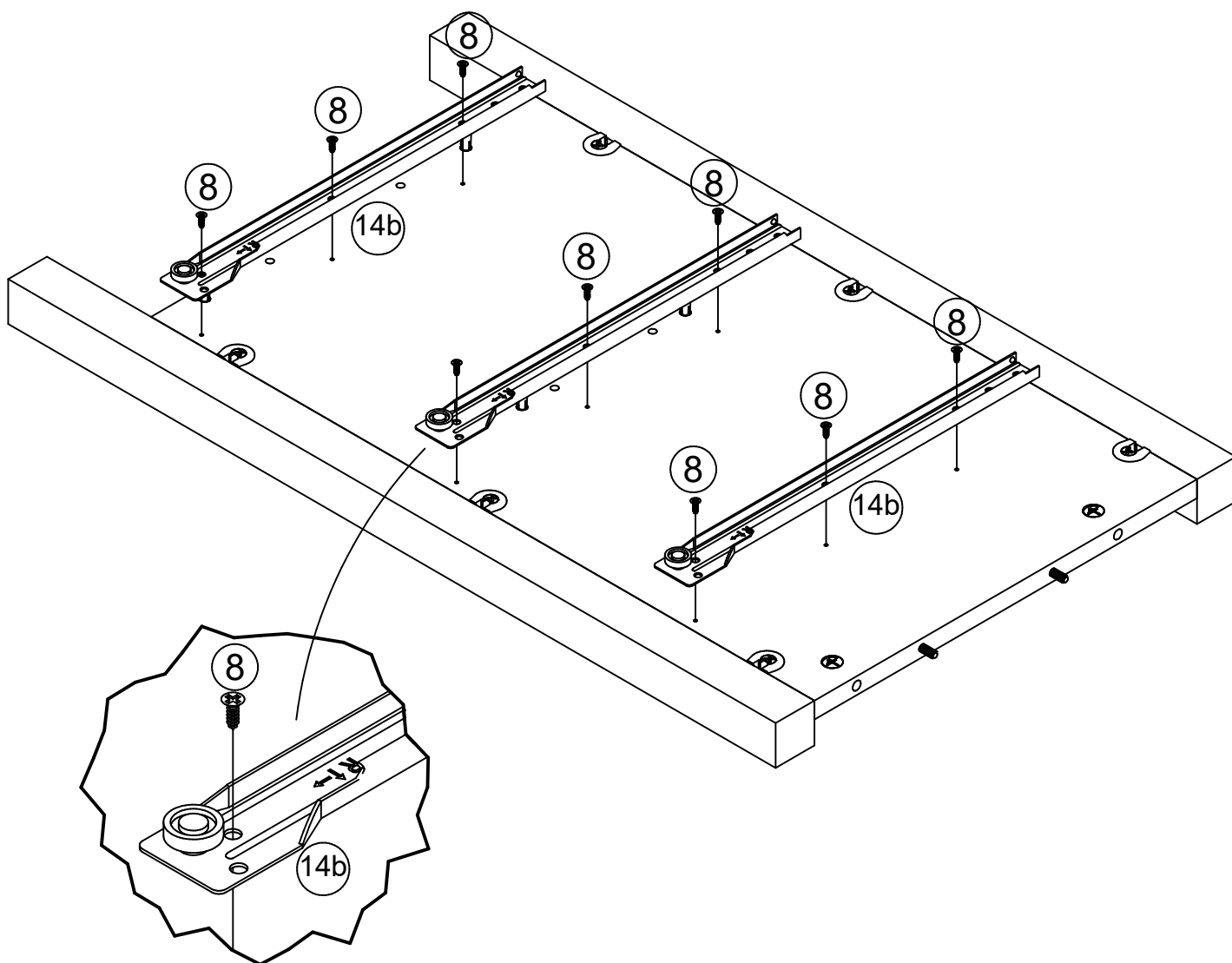

STEP 8

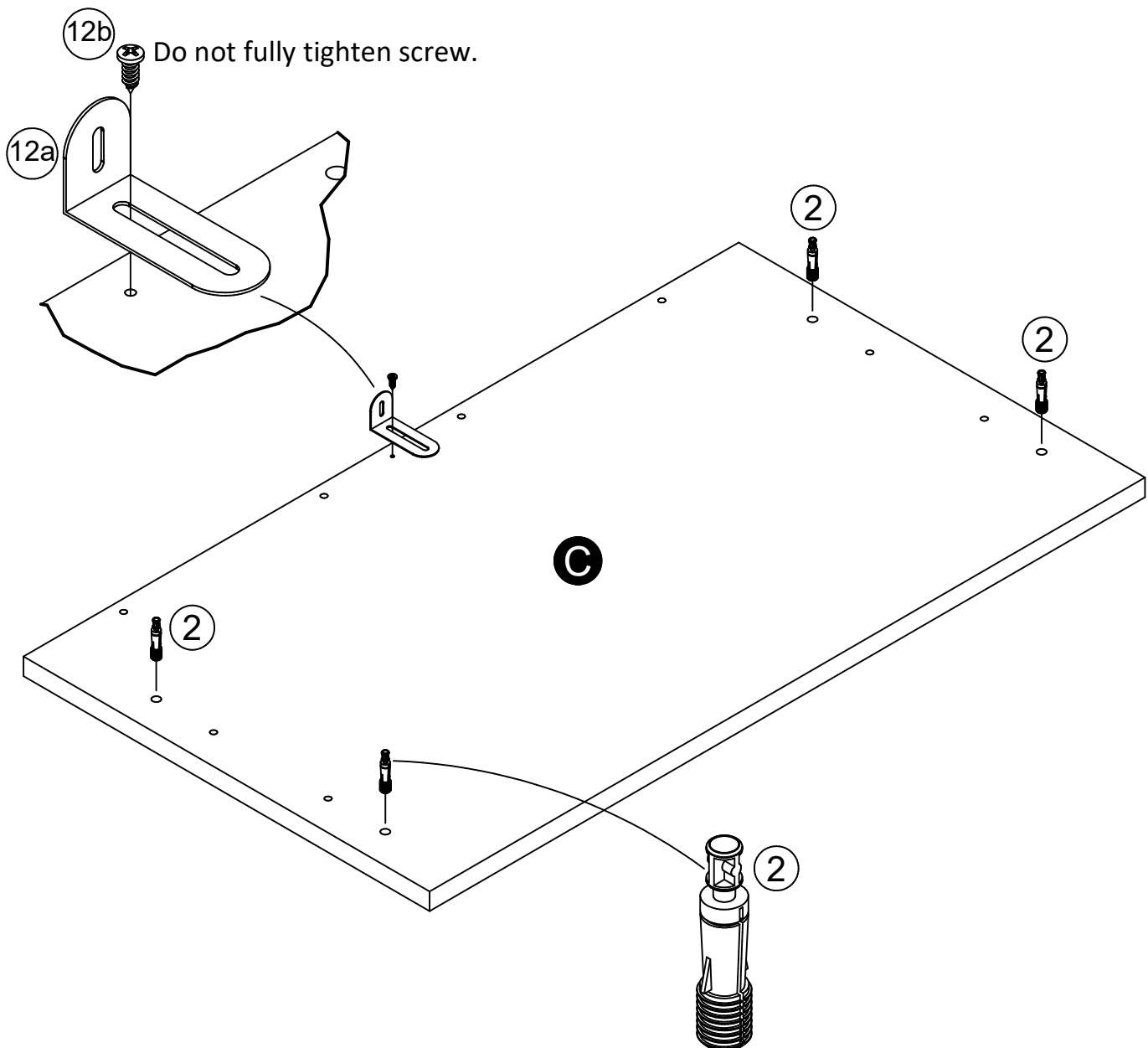
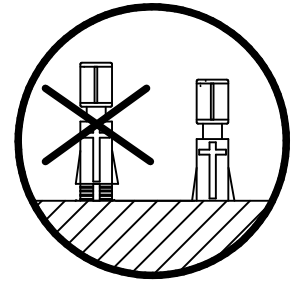
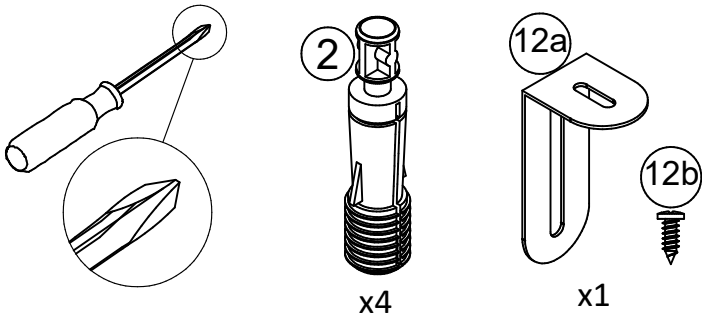

STEP 9

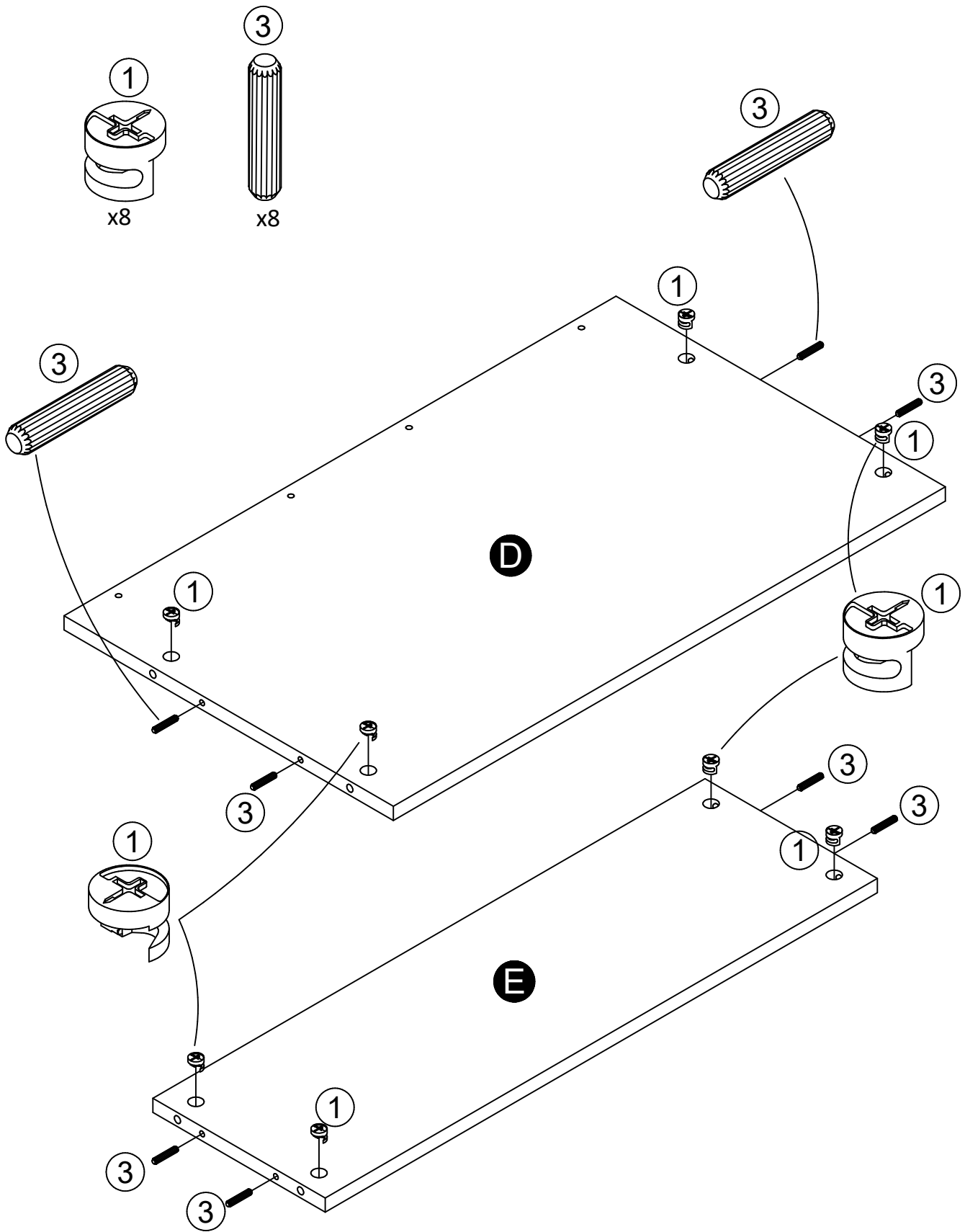

STEP 10

3

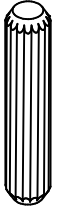

x4

3

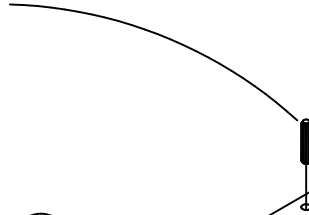
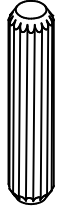

3



Note: Wood dowels (3) will insert into the end with the larger holes.

3



3

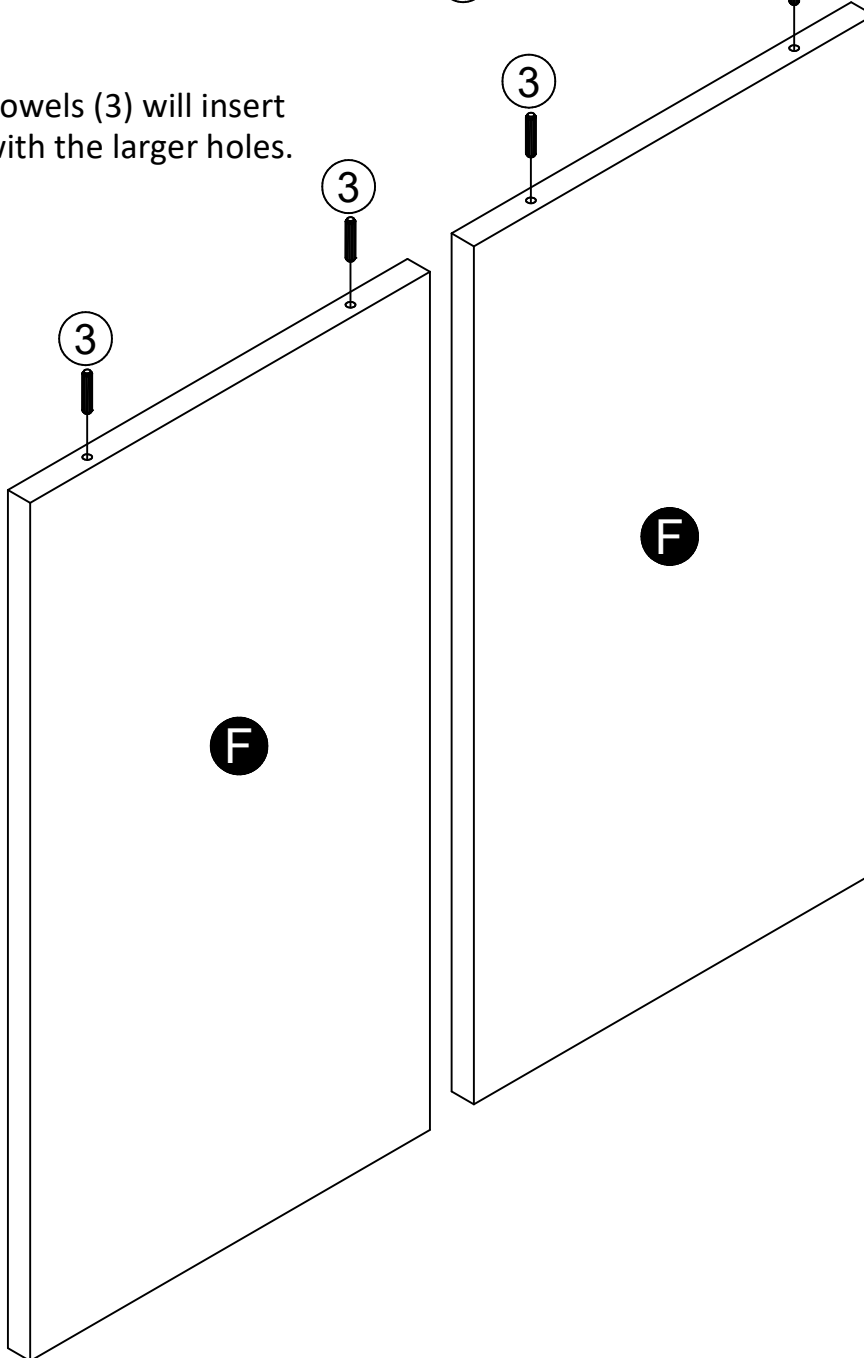

STEP 11

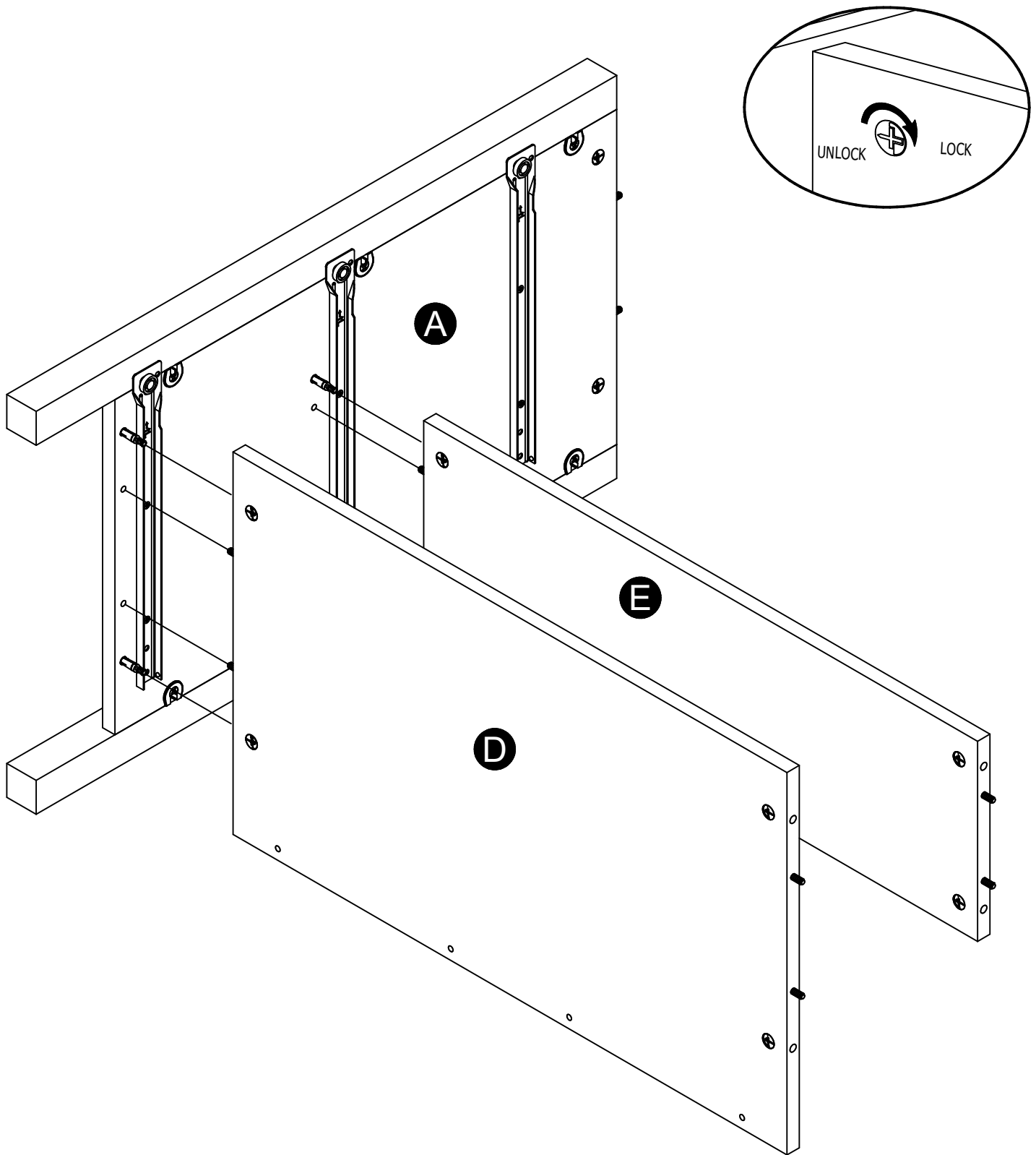

STEP 12

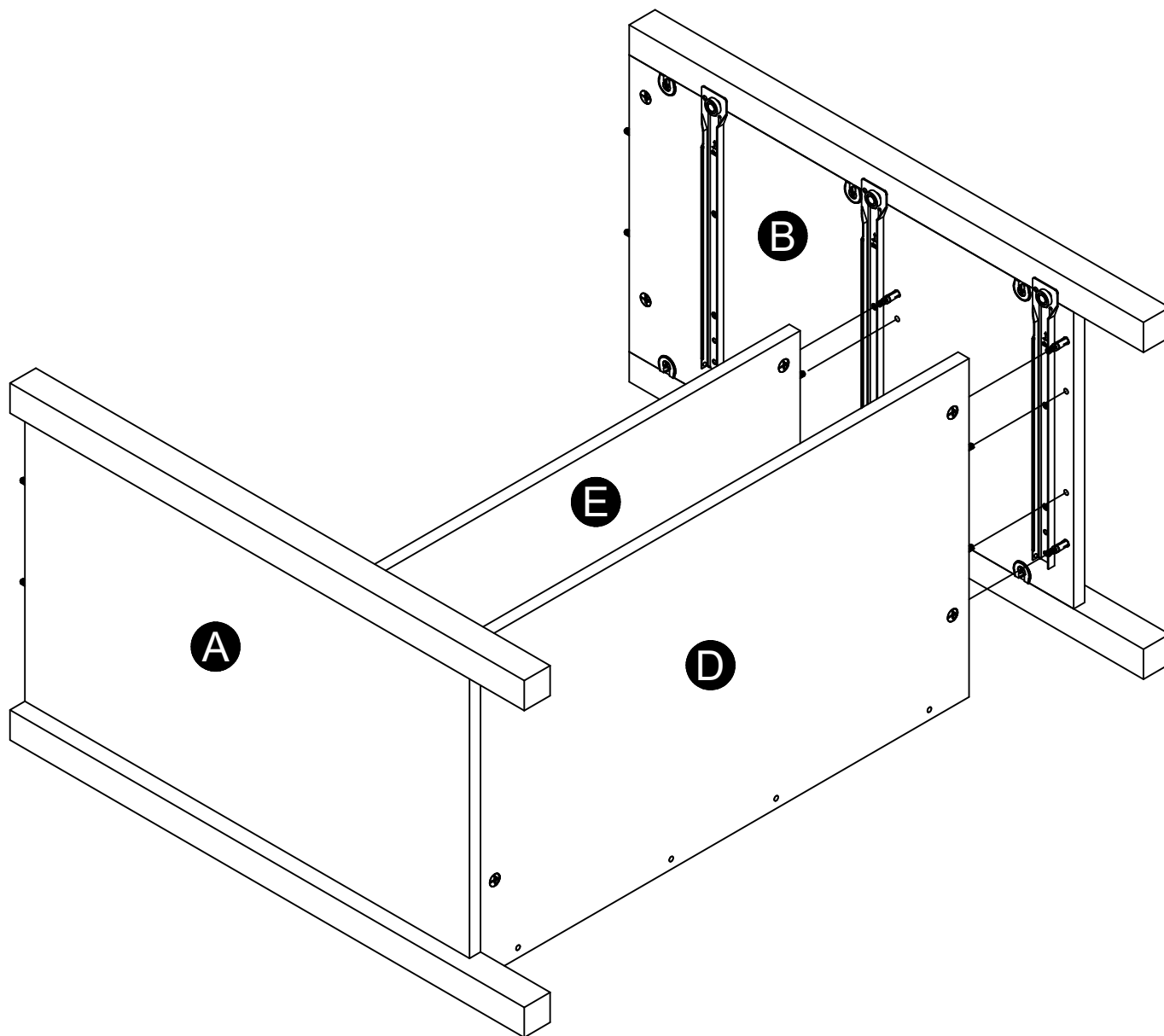
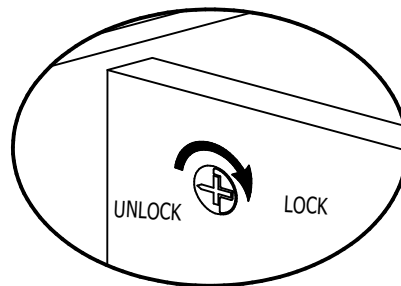
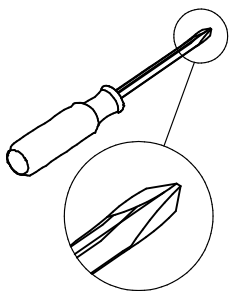

STEP 13

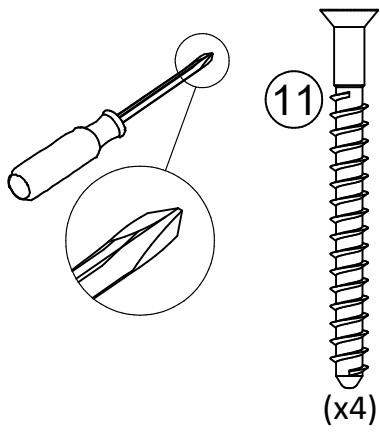

Note: Wood dowels at this end.

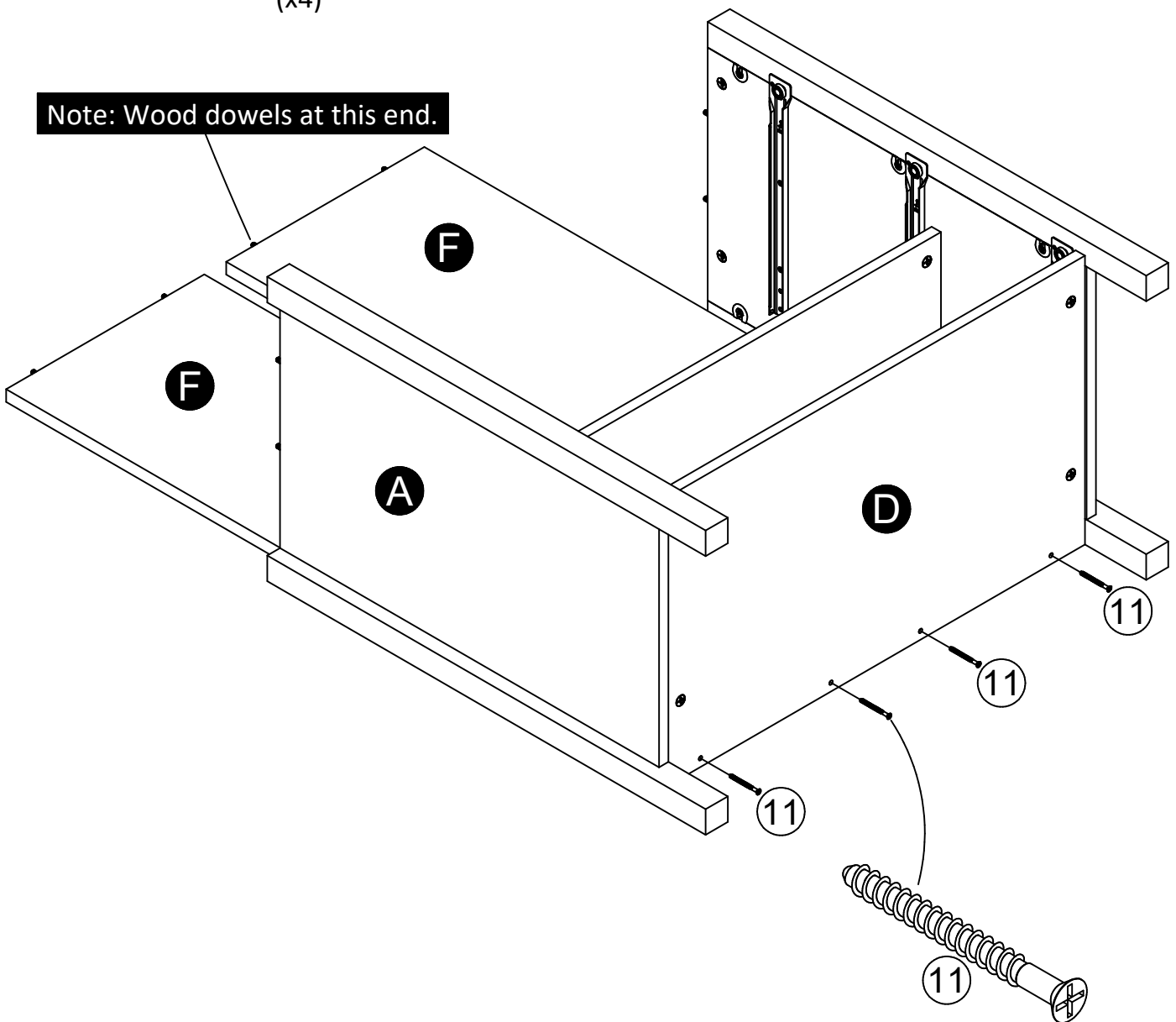

STEP 14

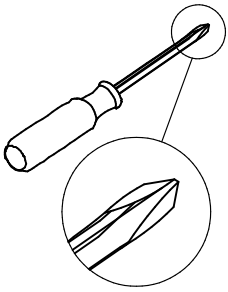

Attach the top (C) as shown making sure the wood dowels (3) into the two backs (F) engage with the holes along the back edge of the top.

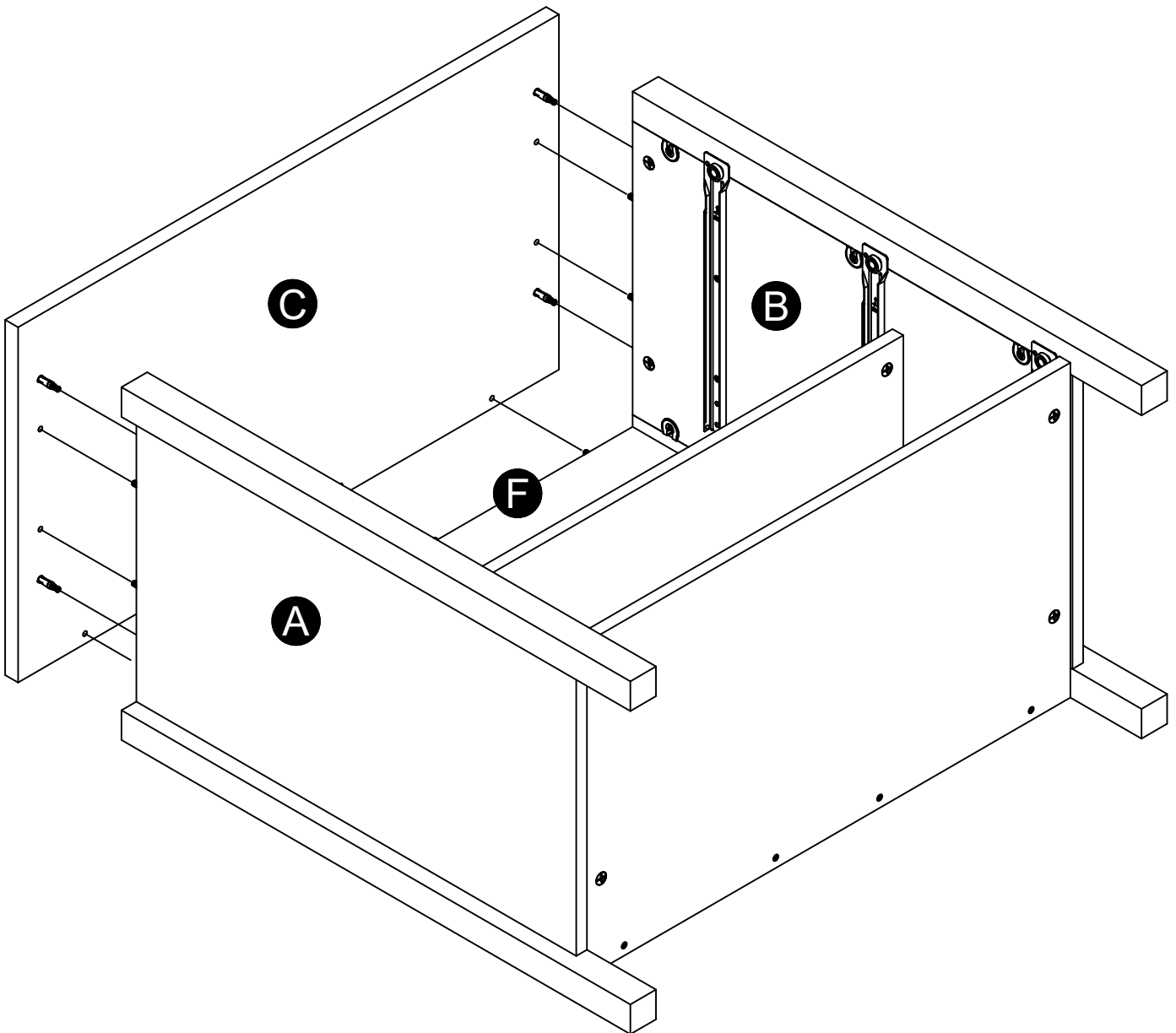

STEP 15

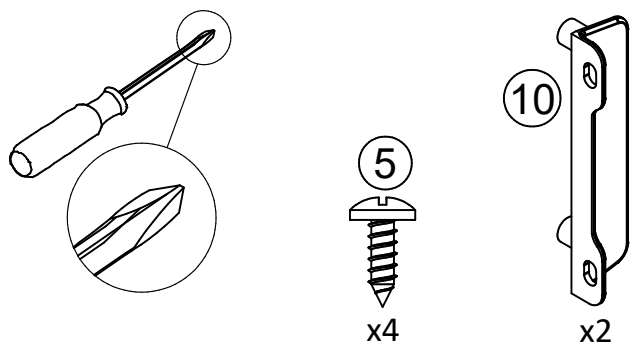

Note: Steps 15 - 20 you will assemble the upper drawer. You will use the smaller drawer sides, drawer back and smaller drawer brackets (10).

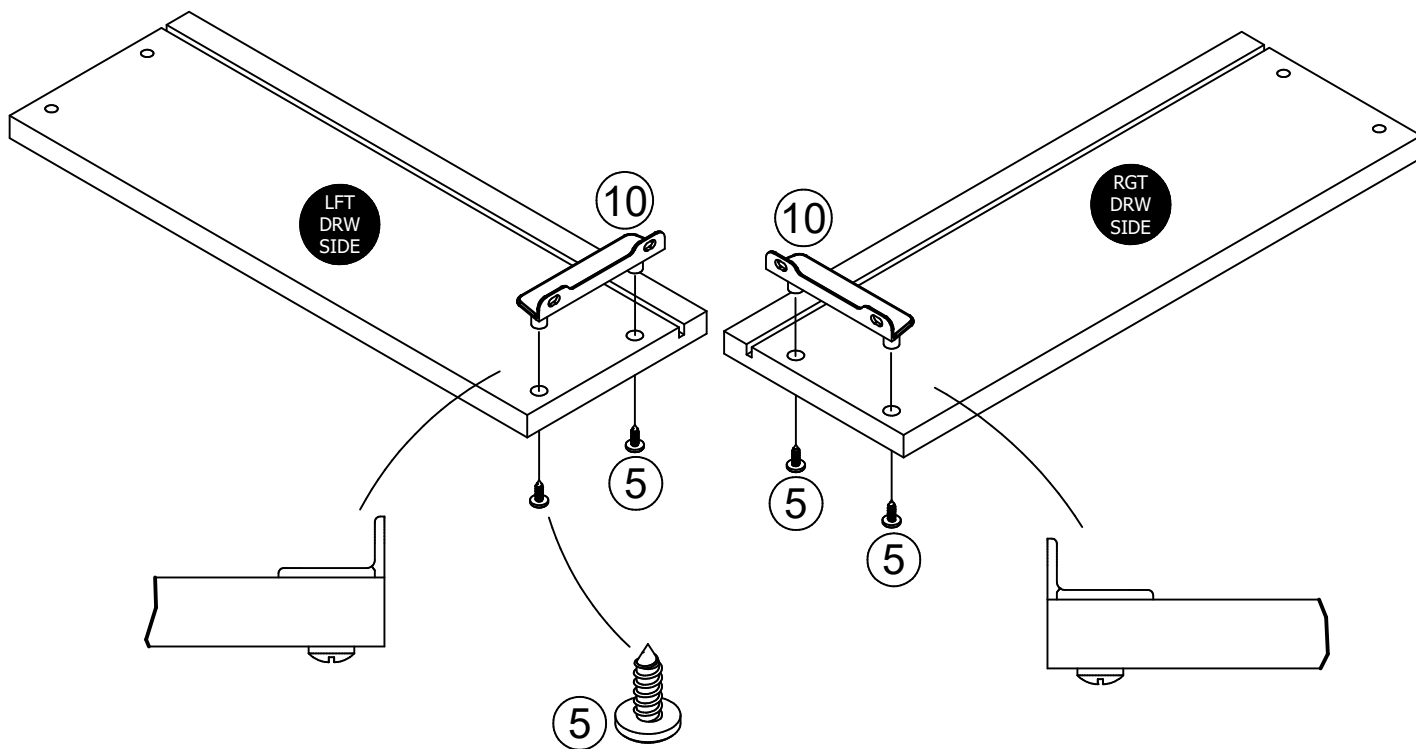

STEP 16

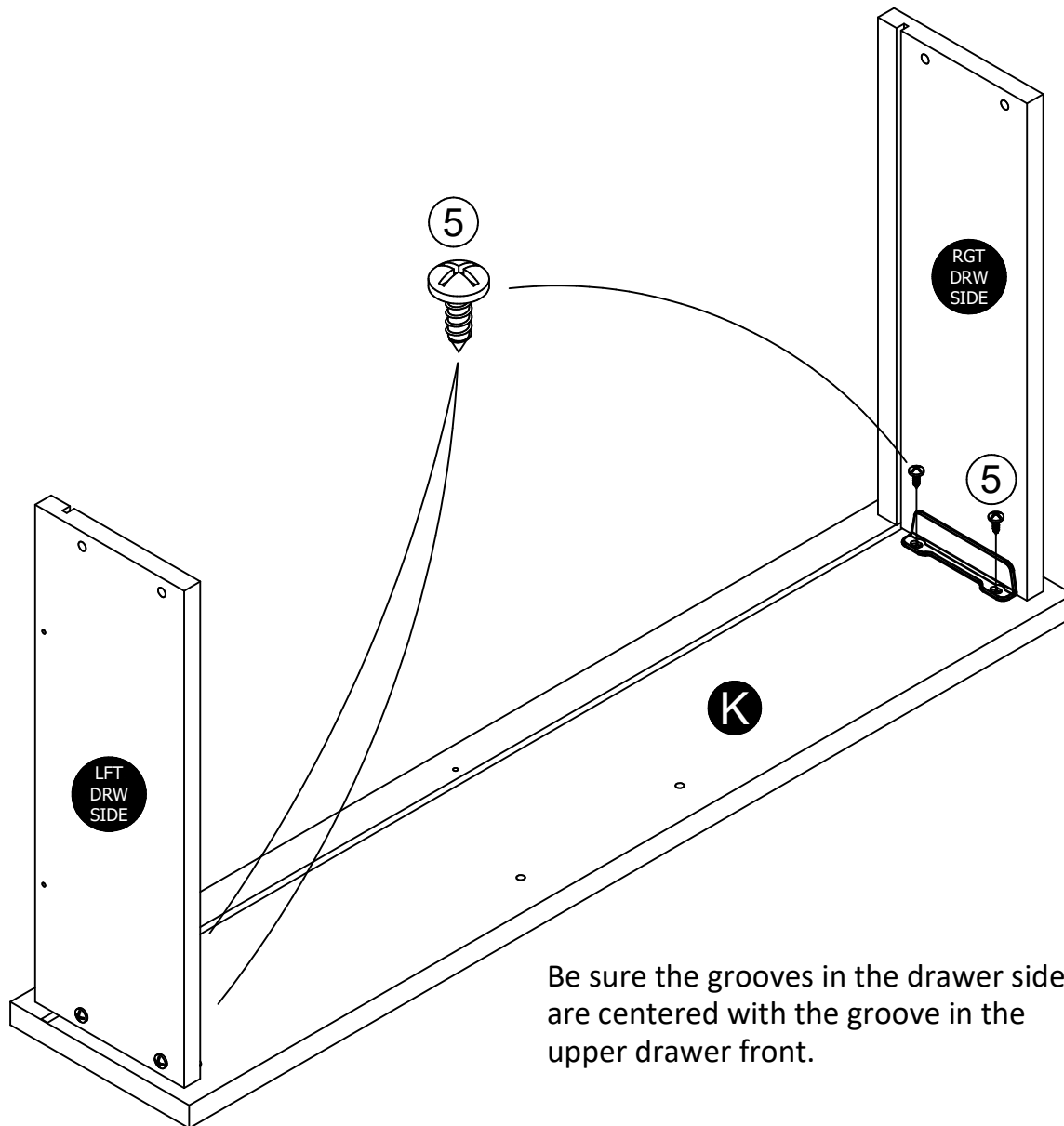
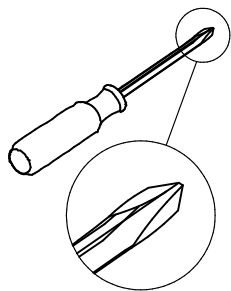

Be sure the grooves in the drawer sides are centered with the groove in the upper drawer front.

STEP 17

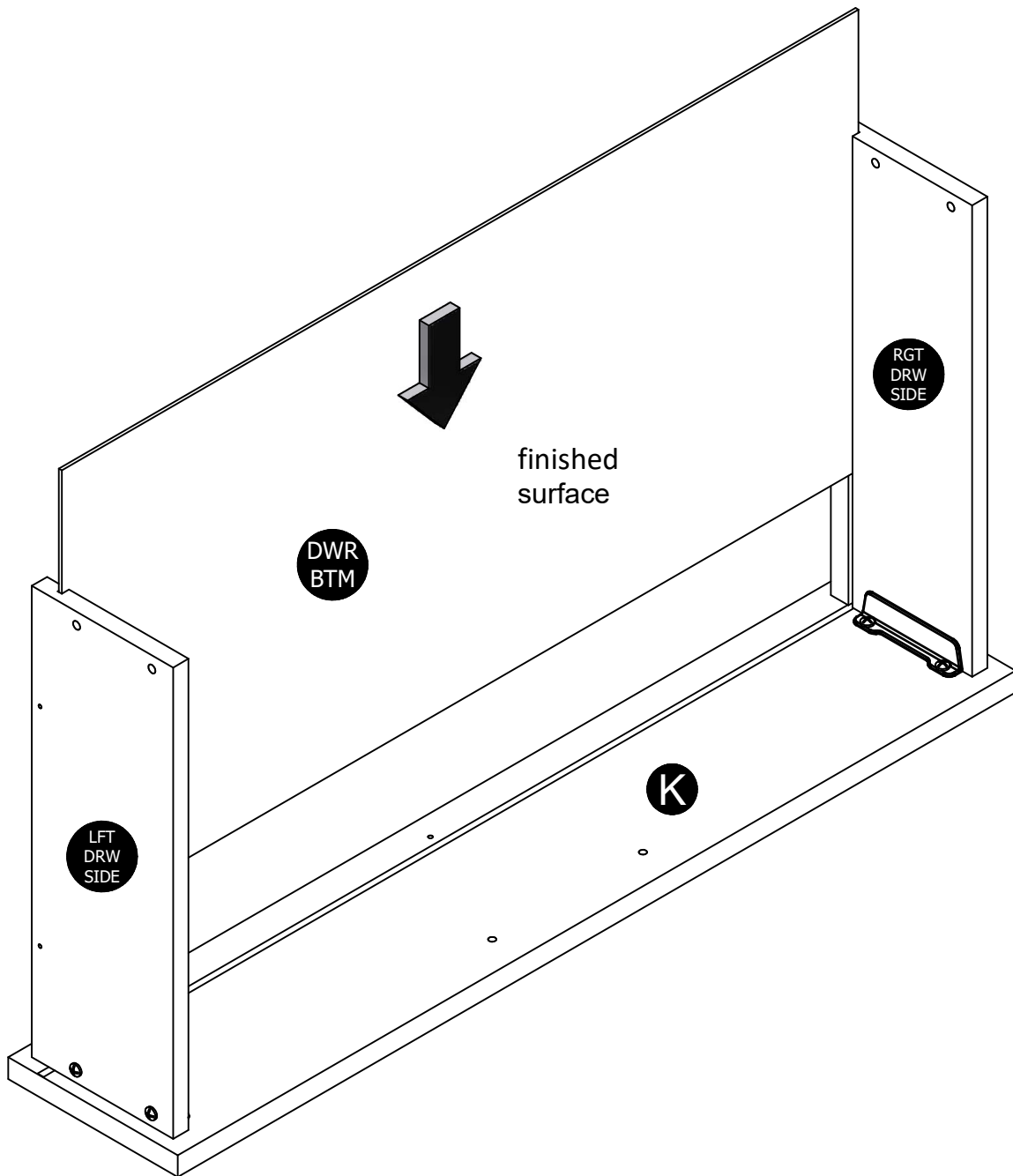

STEP 18

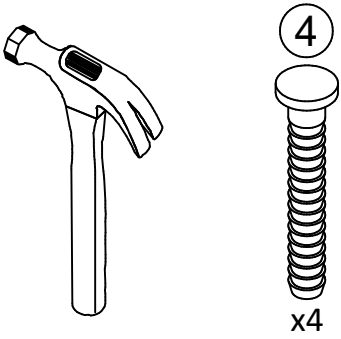

Note: You will need to tap the drive fasteners (4) with a hammer to securely fasten.

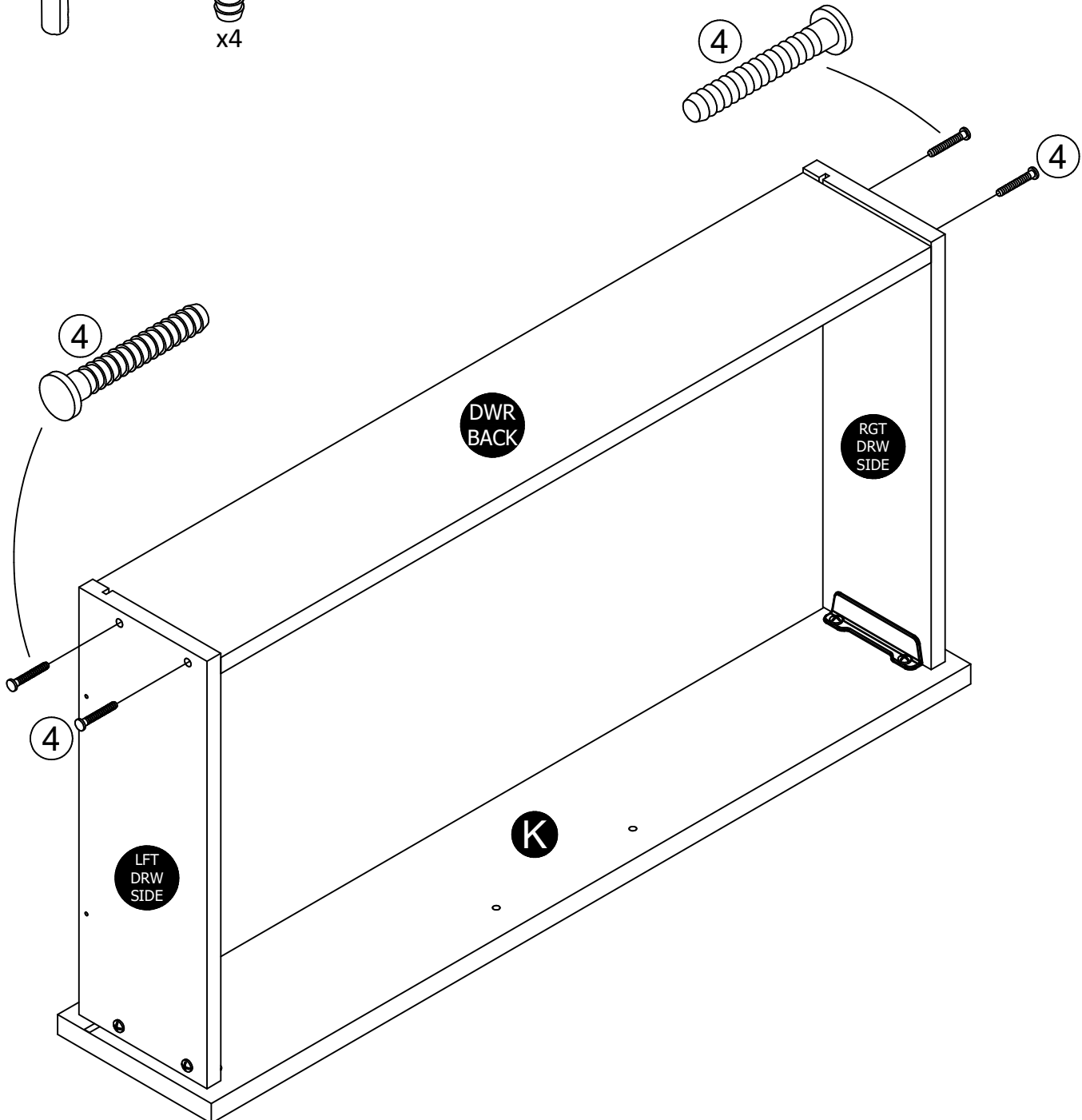

STEP 19

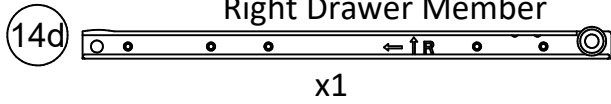
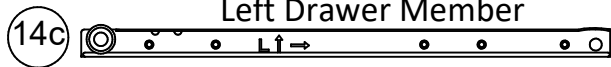
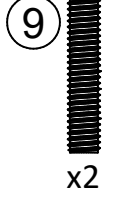
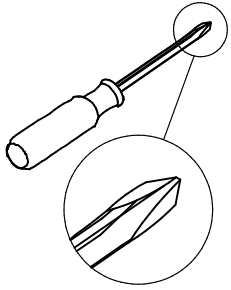

Attach the slides first and then the handle.

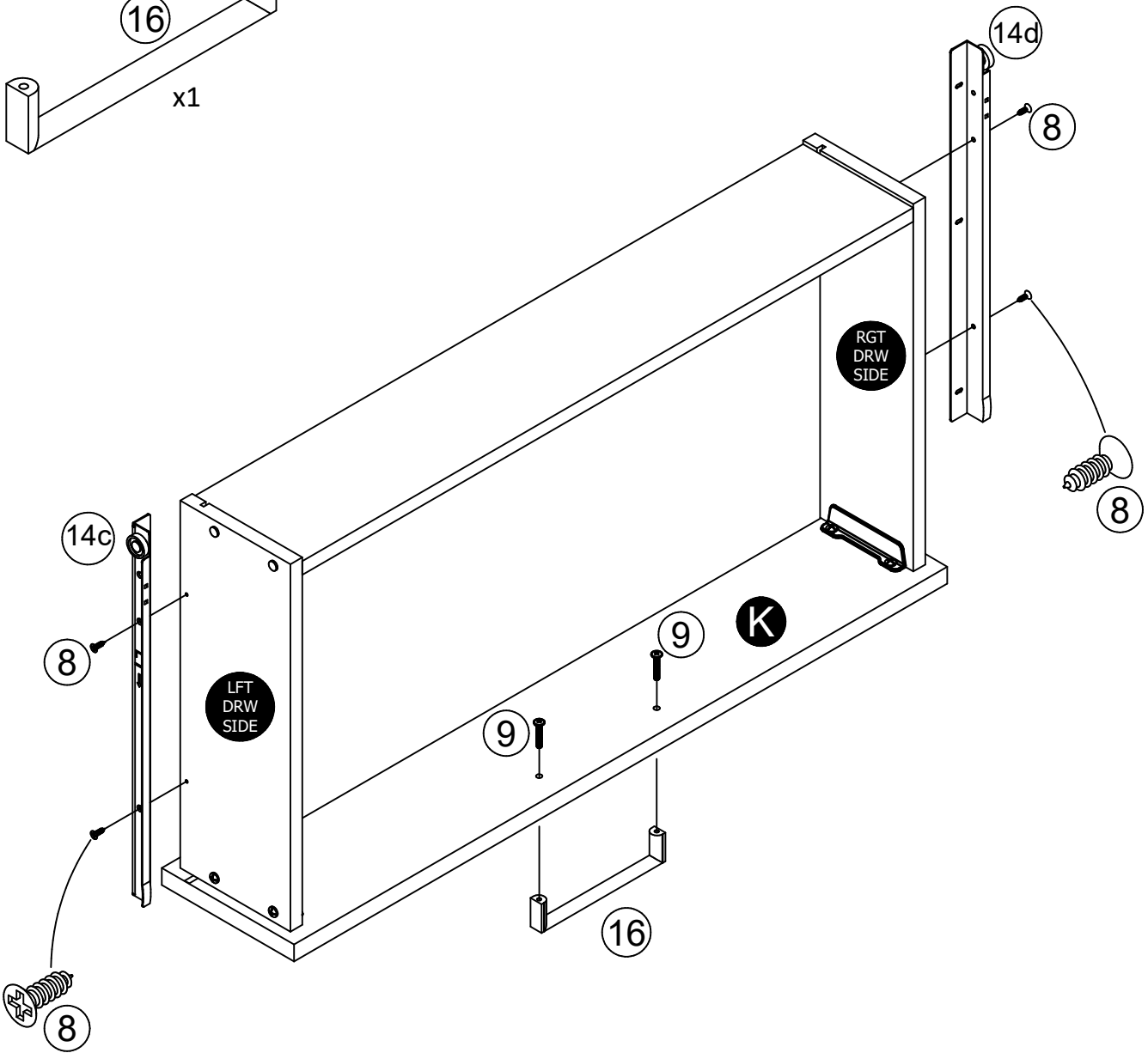
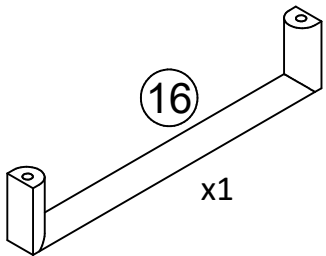

STEP 20

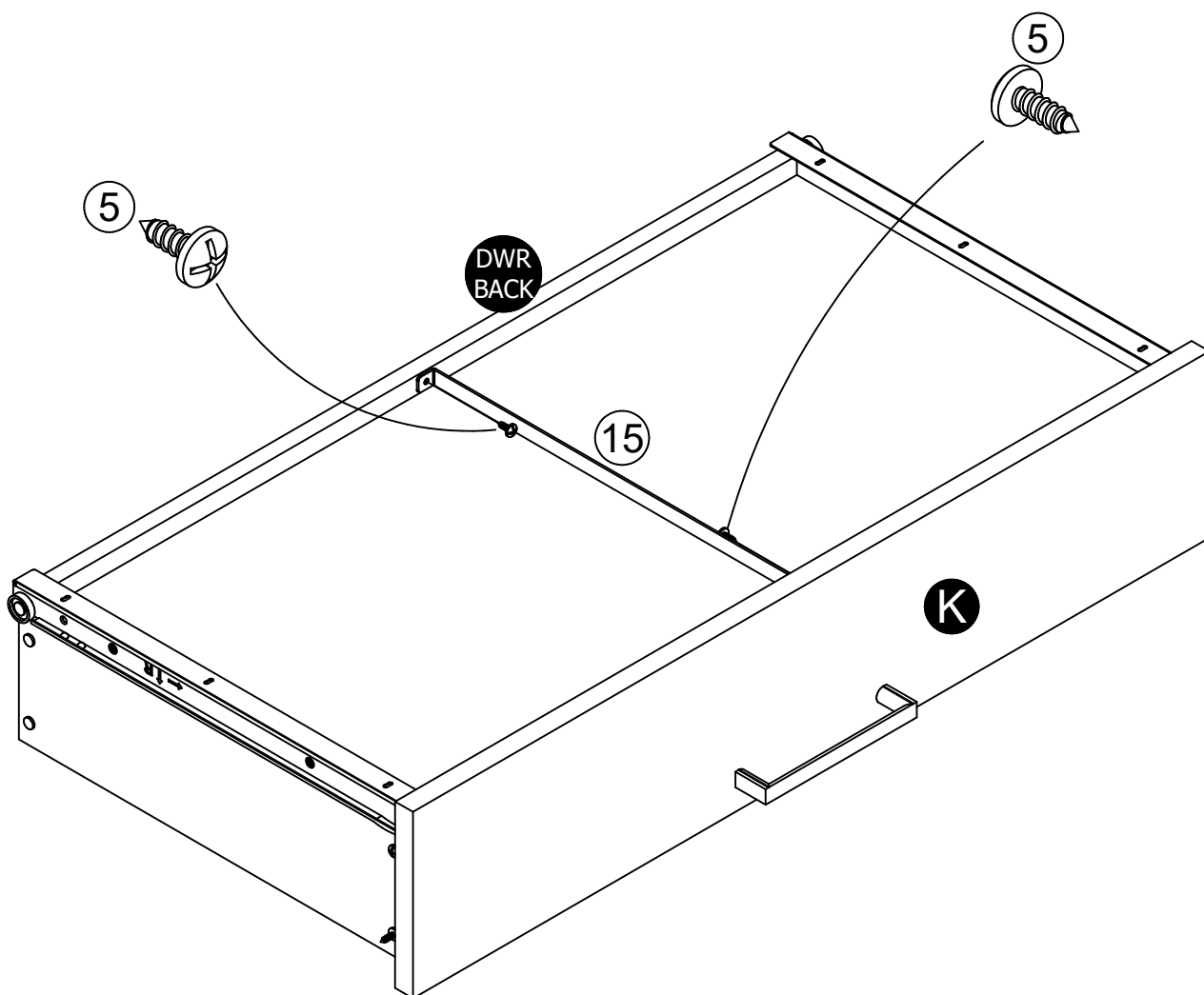
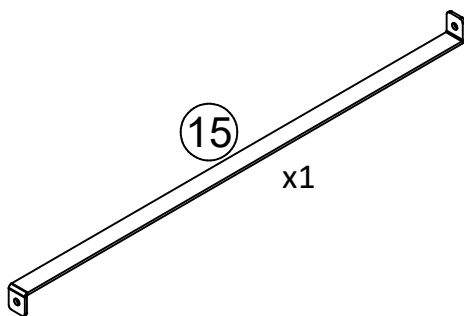
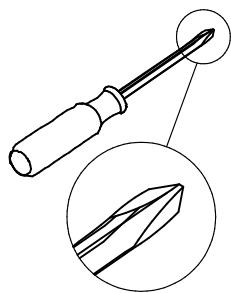

STEP 21

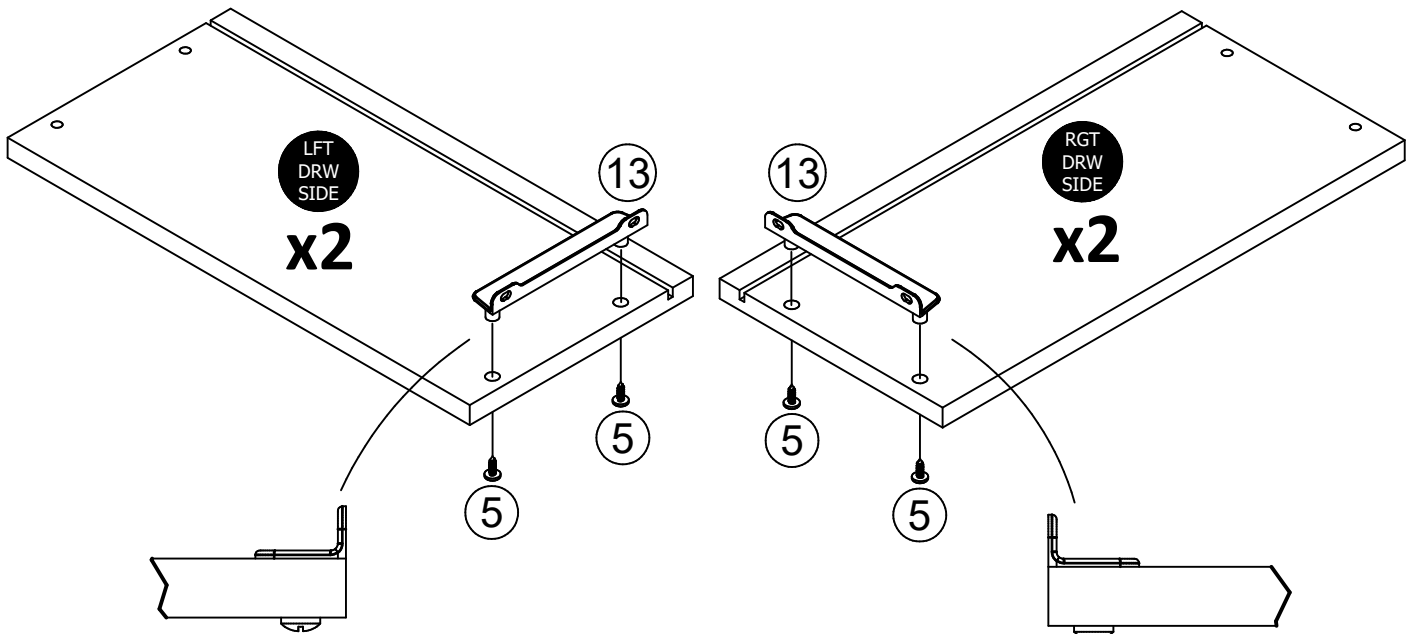
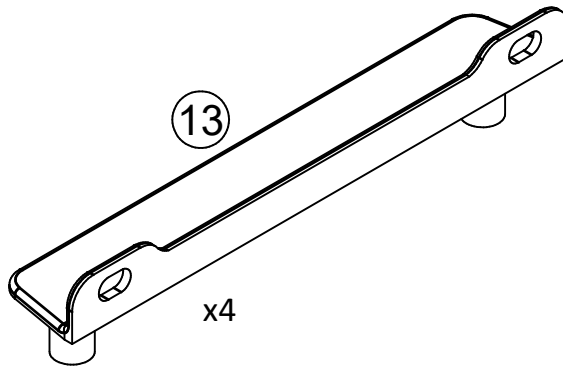
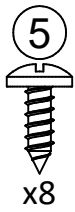
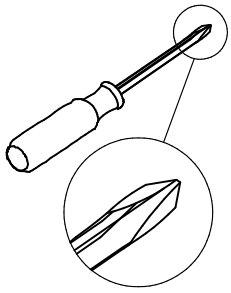

STEP 22

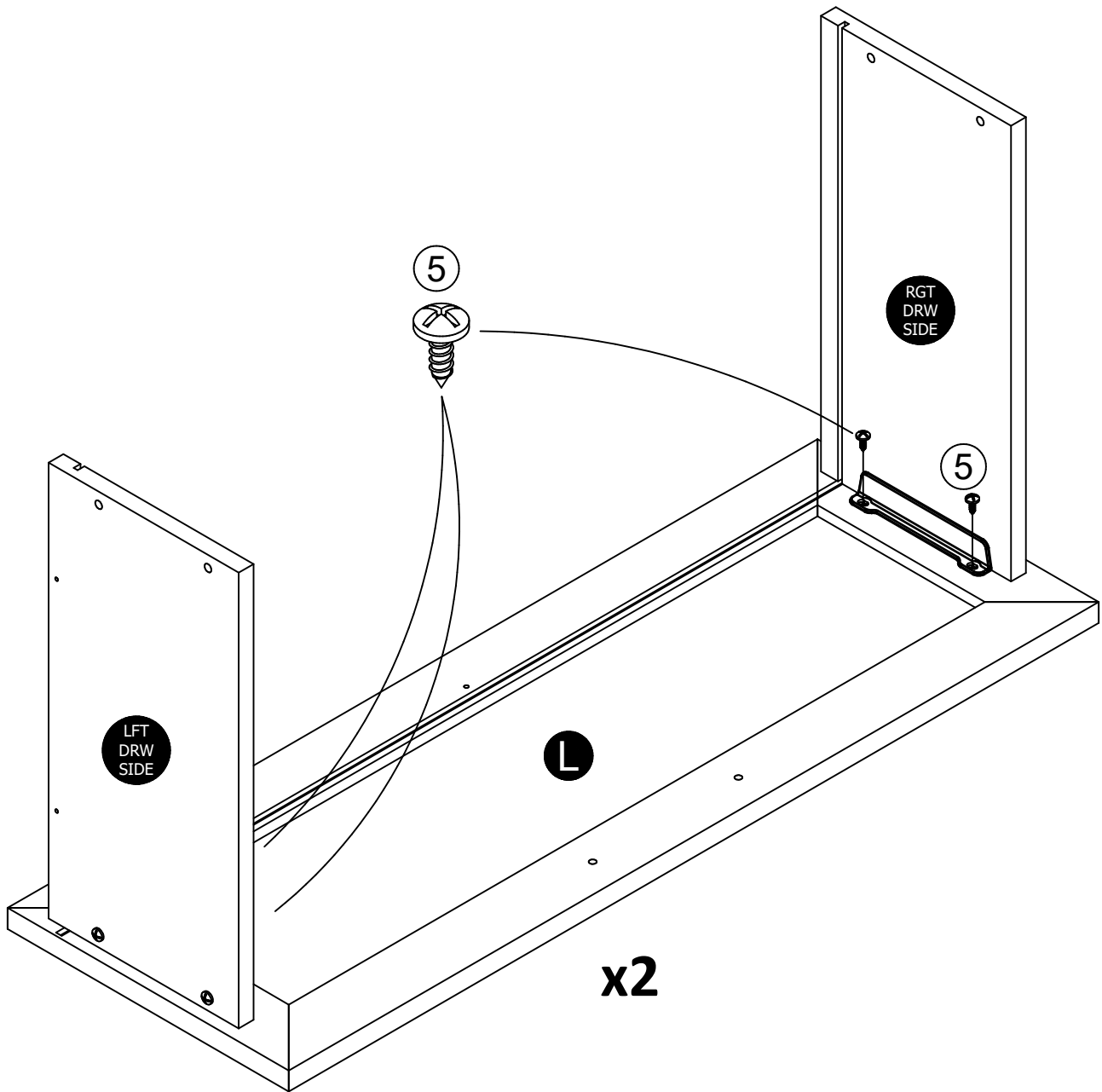
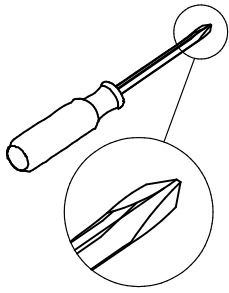

STEP 23

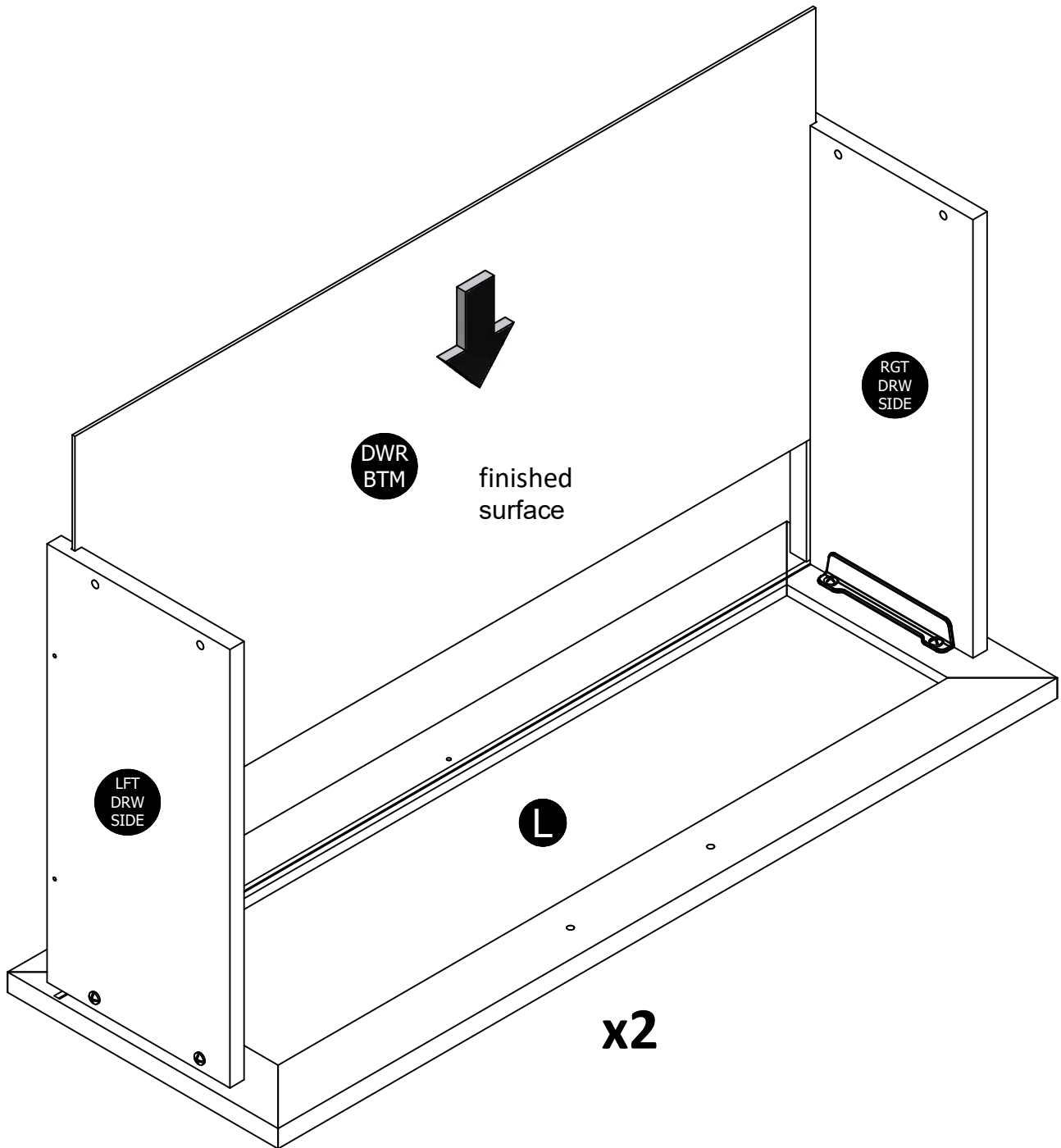

STEP 24

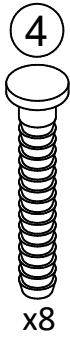
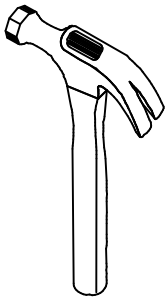

Note: You will need to tap the drive fasteners (4) with a hammer to securely fasten.

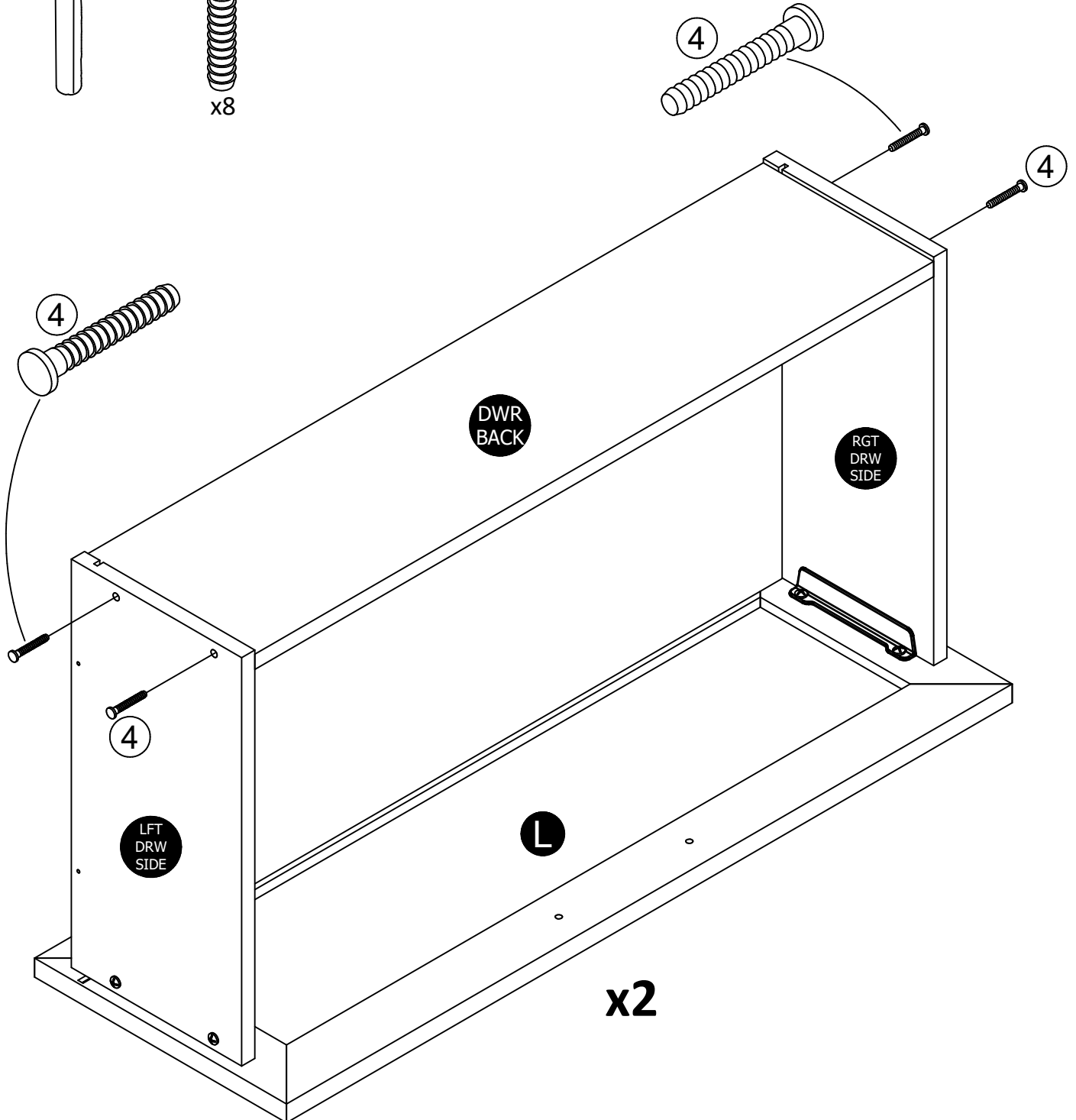

STEP 25

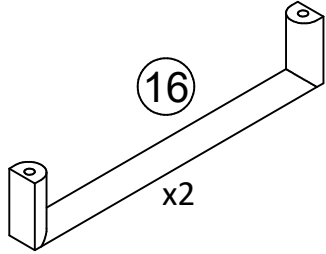
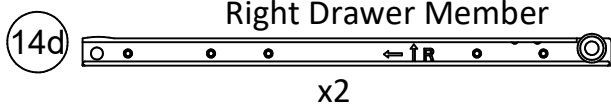
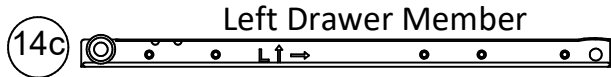
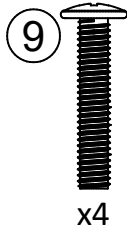
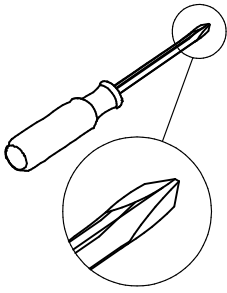

Attach the slides first and then the handle.

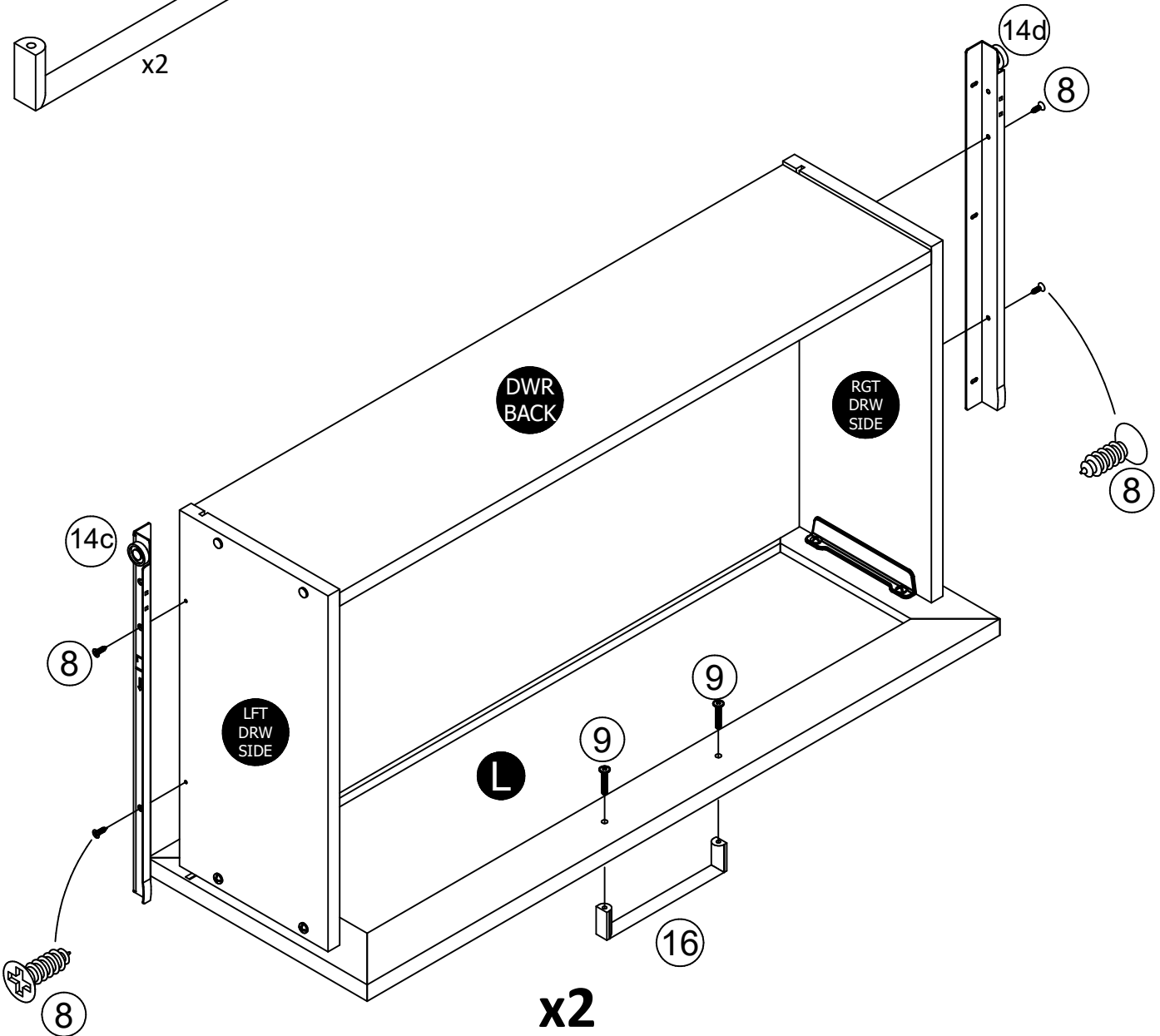

STEP 26

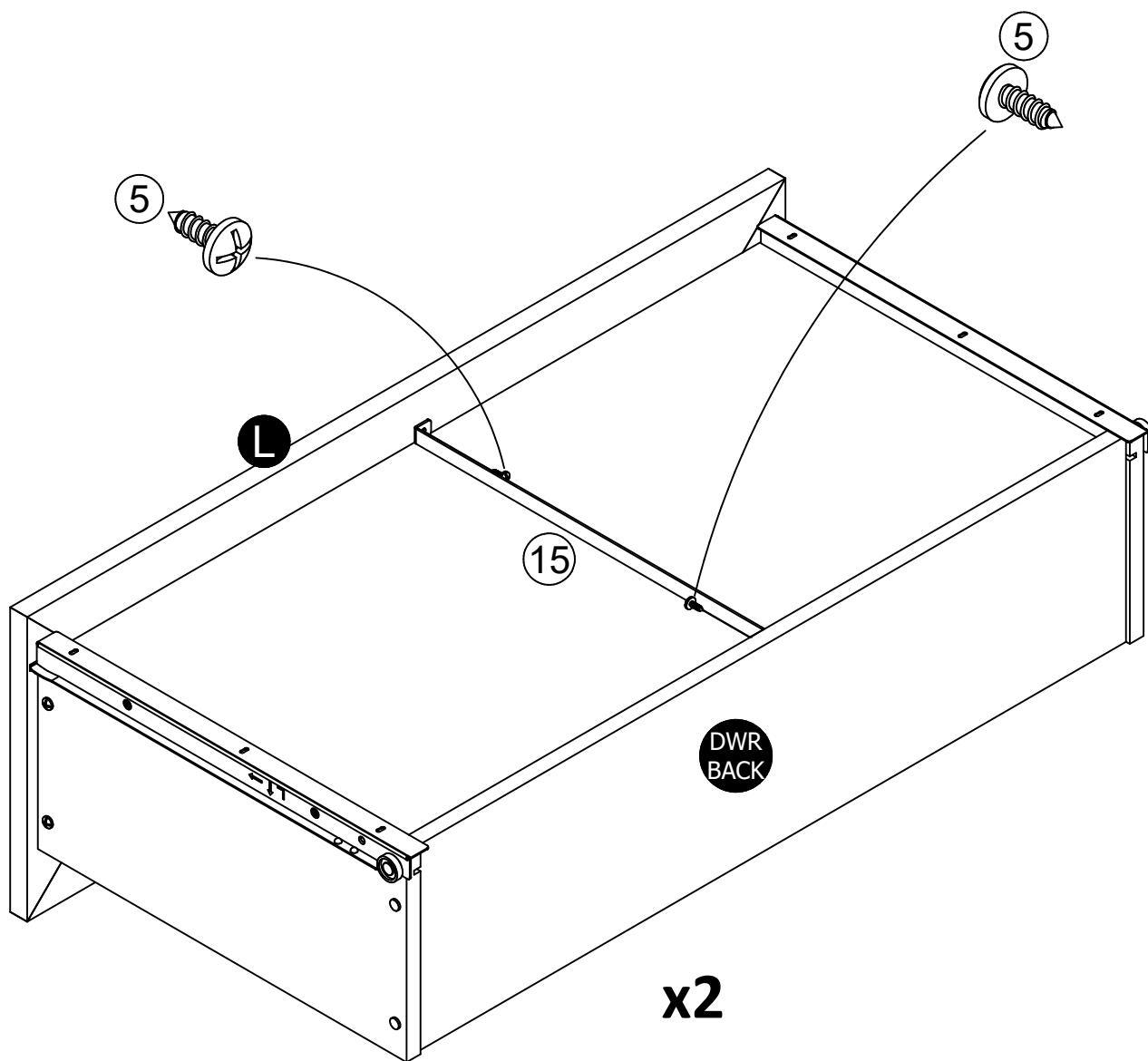
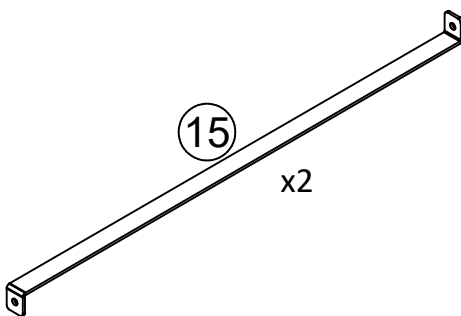
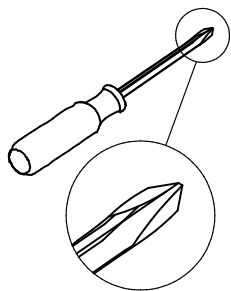

STEP 27

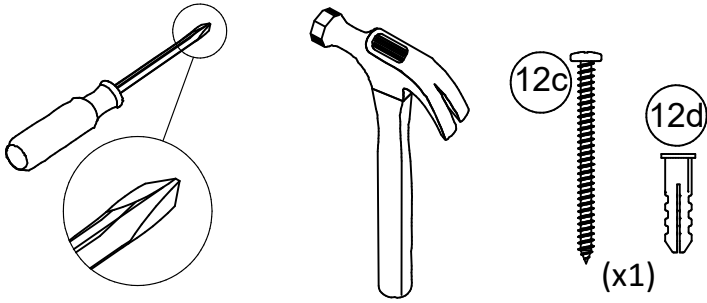

For Masonry, Concrete, or other wall materials:

Consult your local hardware store for appropriate anchors to securely attach the safety bracket.

IMPORTANT: THIS UNIT MUST BE SECURE TO THE WALL TO HELP PREVENT TIPOVER. FOLLOW THESE INSTRUCTIONS TO INSTALL THE ANTI-TIPPING SAFETY BRACKET PROVIDED WITH THIS PRODUCT.

OPTION 1: Attachment into a wall stud (preferred method)

Using a stud finder, locate a stud in the wall. Place your unit against the wall, with the safety bracket aligned in this location. To make driving the screw easier, you can drill a 1/8" diameter pilot hole (3mm) through the safety bracket into the stud. Drive the screw through the safety bracket into the wall stud. Tighten the screw that was not fully tightened in step 8.

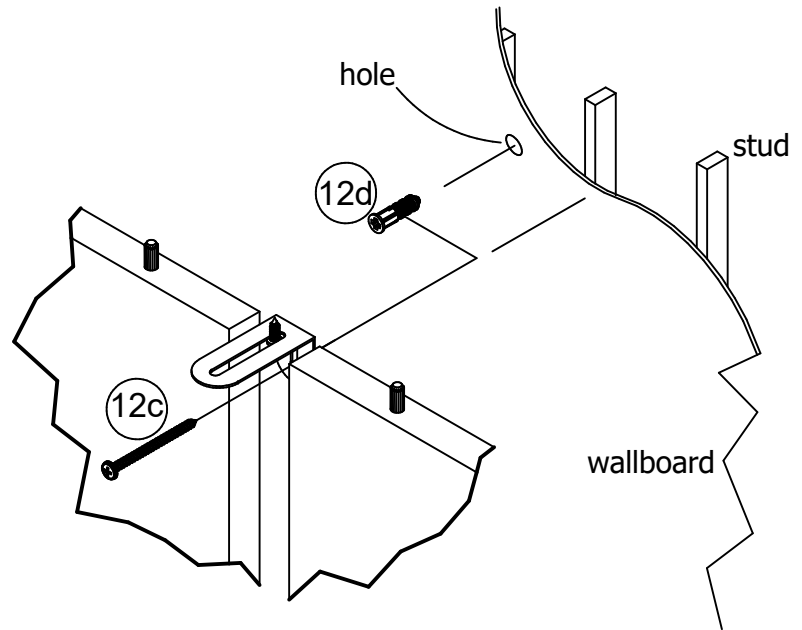

OPTION 2: Attachment into drywall

Locate your unit where desired against a wall and mark the wall through the safety bracket, then move your unit aside. Drill a 3/16" diameter hole (5mm) into the wallboard. Tap the wall anchor into the hole until it is flush. Move your unit into location and fasten the wall bracket to the wall anchor with the screw. Tighten the screw that was not fully tightened in step 8.

⚠ WARNING



Children have died from furniture tip over. To reduce the risk of furniture tip over:

- ALWAYS install tip over restraint provided.
- NEVER put a TV on this product.
- NEVER allow children to stand, climb or hang on drawers, doors, or shelves.
- NEVER open more than one drawer at a time.
- Place heaviest items in the lowest drawers.



STEP 28

Note: The drawer bracket holes are slotted. Drawer fronts can be adjusted by loosening screws, making needed adjustments and retightening screws.

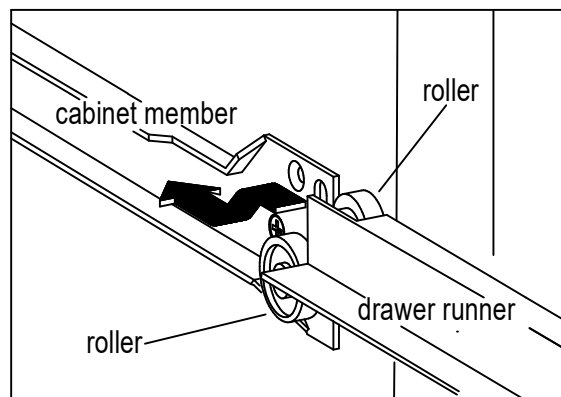
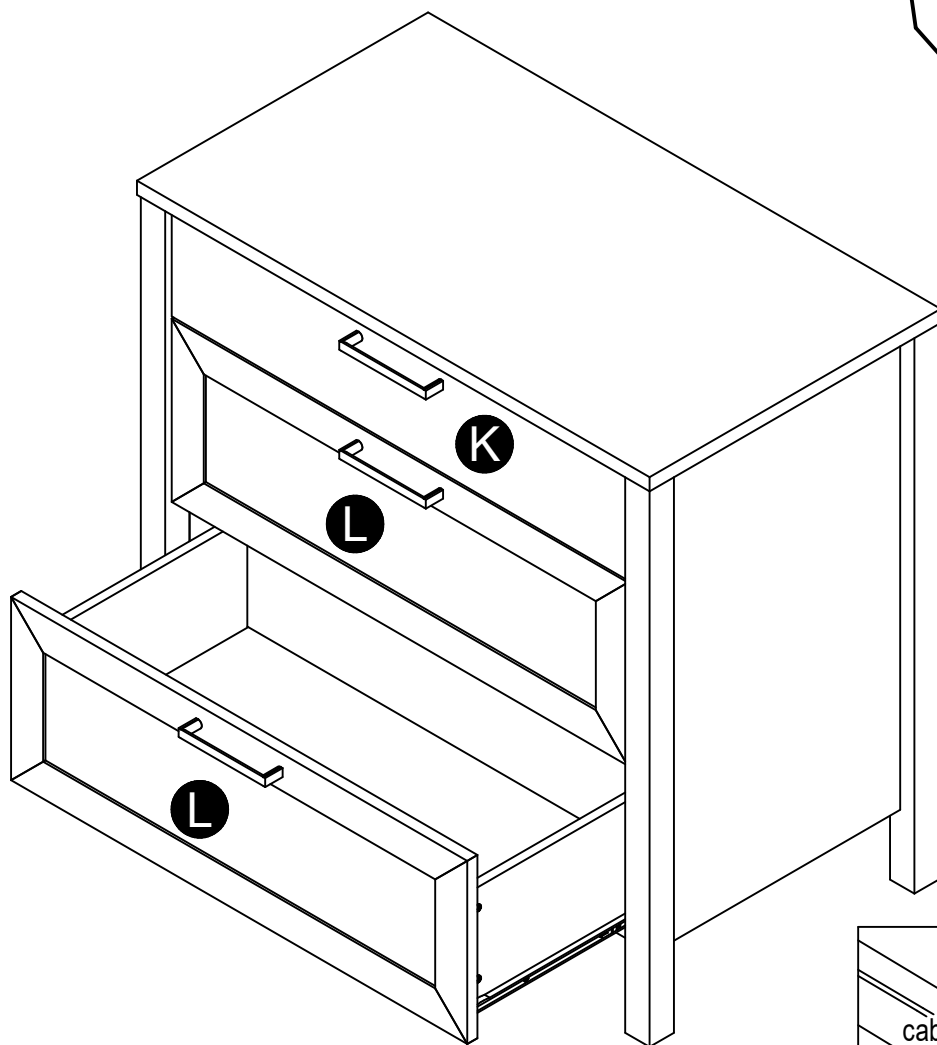
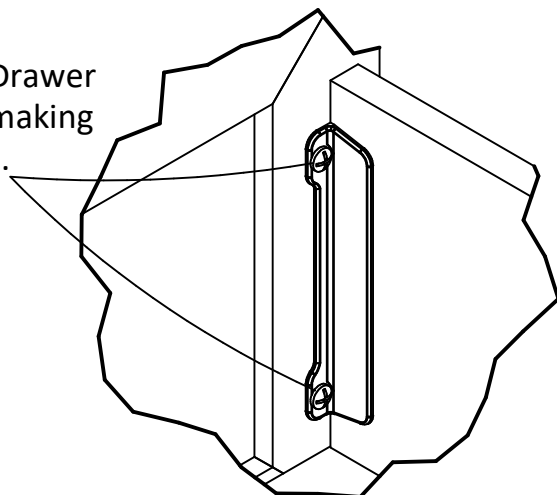

Maximum Loads

This unit has been designed to support the maximum loads shown. Exceeding these load limits could cause sagging, instability, product collapse, and/or serious injury.

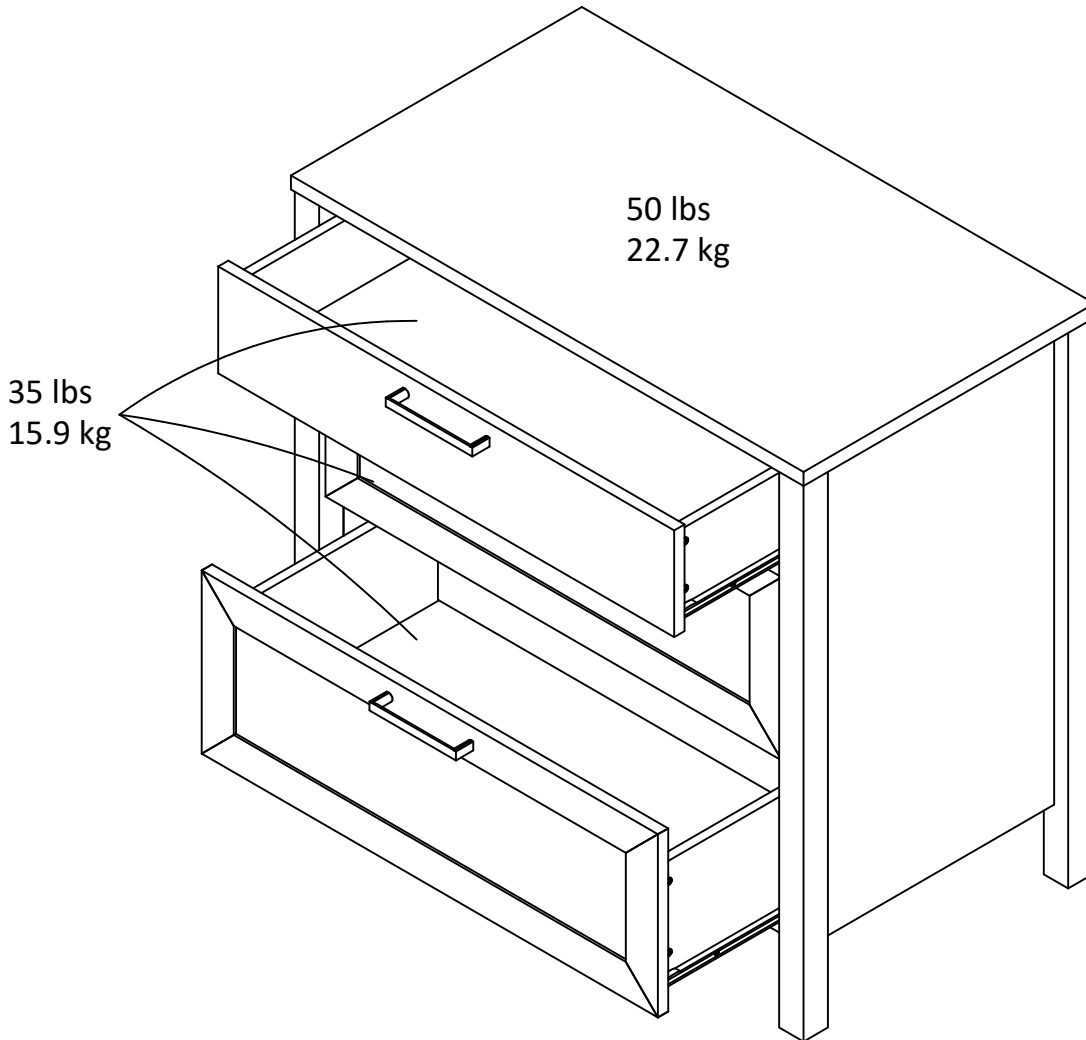

Warning: Risk of injury to persons - do not place a television on this furniture. This furniture is not approved for use with a television.

Certificate of Conformity

1. This certificate applies to the Dorel Home Furnishings, Inc. product identified by this instruction manual.
2. This certificate applies to compliance of this product with the CPSC Ban on Lead-Containing Paint (16 CFR 1303).
3. This product is distributed by: Dorel Home Furnishings, Inc.
410 East First Street South
Wright City, MO 63390
636-745-3351
4. Site of Manufacture: Tiffin OH
5. See front page of instruction manual for date of manufacture.

Register your product to receive the following:



- * New trend details - sneak peek on what's new
- * Surveys - have a voice within our community
- * Exclusive deals and discount codes
- * Quick and easy replacement part service

To register your product, visit ameriwoodhome.com

5 Star Rating



Visit your local retailer's website, rate your purchased product and leave us some feedback!

We would like to extend a big "Thank You" to all of our customers for taking the time to assemble this Ameriwood Home product, and to give us your valuable feedback.

*Thank
You!*

Español

Cubierta Delantera

Este libro de instrucciones contiene información **IMPORTANTE** de seguridad. Por favor lea y manténgalo para referencia en el futuro.

No Regrese este producto! Comuníquese con nuestro amistoso equipo de servicio al cliente para obtener ayuda.

Llámenos al: 1-800-489-3351 (Gratis) Lunes - Viernes 9am - 5pm CST

Visitar: www.ameriwoodhome.com

PRECAUCION

Este mueble puede volcarse y causar graves heridas y/o muerte.

Anclar el mueble a un poste de madera en la pared (si esto se requiere).

No Permita que los niños monten el mueble.

Mantenga los artículos más pesados en los cajones de abajo.

Consejos Útiles (página 2)

- Abra su artículo en el área donde usted planea utilizarlo para evitar levantar y moverlo menos
- Identificar, ordenar y contar las piezas antes de intentar ensamblar
- Las clavijas de compresión se golpean con un martillo
- Las diapositivas están marcadas con una R (derecha) y L (izquierda) para la colocación correcta
- Asegúrese de que siempre este el punto localizado en la parte superior de bloqueador de leva este volteado hacia borde exterior
- Utilizar todos los clavos para el panel de atrás y distribuirlos por igual
- El panel de atrás debe utilizarse para asegurarse de que la unidad quede fija y firme
- No use químicos fuertes ni limpiadores abrasivos en este artículo
- Nunca empuje, tire ni arrastre los muebles

Antes de Que Empieces (página 3)

- Lea cuidadosamente cada paso y siga el orden correcto

- Separar y contar todas sus piezas y hardware

- Dése suficiente espacio para el proceso de ensamble

- Tenga las siguientes herramientas: destornillador de cabeza plana, #2 cabeza Phillips

Destornillador y martillo

- Precaución: Si usa un taladro electrónico o un destornillador eléctrico para atornillar, por favor asegúrese que deje de atornillar cuando el tornillo este apretado. Fallar hacer esto puede causar barrer el tornillo.

Sistema de fijar el bloqueo de leva (página 3)

Este sistema de fijar el bloqueo de leva será usado en todo el proceso ensamble.

Español

Página 9 / 10

Deberá golpear el conector (7) con un martillo para insertarlo completamente. Asegúrese de que el conector esté colocado como se muestra antes de golpearlo en el orificio.

Página 12 / 13

Gire en el sentido de las agujas del reloj para fijarlo en su sitio.

Página 16

No apriete completamente el tornillo.

Página 18

Nota: Las clavijas de madera (3) se insertarán en el extremo con los agujeros más grandes.

Página 22

Fije la parte superior (C) como se muestra, asegurándose de que las clavijas de madera (3) en las dos partes traseras (F) encajan con los agujeros a lo largo del borde posterior de la parte superior.

Página 23

Nota: En los pasos 15 - 20 ensamblará el cajón superior. Utilizará los lados del cajón más pequeños, la parte trasera del cajón y los soportes del cajón más pequeños (10).

Página 24

Asegúrese de que las ranuras de los laterales del cajón estén centradas con la ranura del frente del cajón superior.

Página 26 / 32

Nota: Tendrá que golpear con un martillo los tornillos (4) para que queden bien sujetos.

Página 27

Coloque primero las guías y luego el mango.

Página 33

Coloque primero las guías y luego el mango.

Página 35

Para mampostería, concreto u otros materiales de pared:

Consulte en su ferretería local los anclajes adecuados para fijar el soporte de seguridad.

IMPORTANTE: ESTA UNIDAD DEBE ESTAR FIJADA A LA PARED PARA EVITAR QUE SE VUELQUE. SIGA ESTAS INSTRUCCIONES PARA INSTALAR EL SOPORTE DE SEGURIDAD ANTIVOLCADURAS SUMINISTRADO CON ESTE PRODUCTO.

Español

OPCIÓN 1: Fijación en un montante de la pared (método preferido)

Con un localizador de montantes, localice un montante en la pared. Coloque su unidad contra la pared, con el soporte de seguridad alineado en esta ubicación. Para facilitar la colocación del tornillo, puede perforar un agujero piloto de 1/8" de diámetro (3 mm) a través del soporte de seguridad en el montante. Introduzca el tornillo a través del soporte de seguridad en el montante de la pared. Apriete el tornillo que no se había apretado del todo en el paso 8.

OPCIÓN 2: Fijación en pared de yeso

Ubique su unidad en el lugar deseado contra una pared y marque la pared a través del soporte de seguridad, luego mueva su unidad a un lado. Perfore un agujero de 3/16" de diámetro (5mm) en la pared. Golpee el anclaje de pared en el agujero hasta que esté al ras. Mueva su unidad a su ubicación y fije el soporte de pared al anclaje de pared con el tornillo. Apriete el tornillo que no se había apretado del todo en el paso 8.

Página 36

Nota: Los agujeros de los soportes de los cajones están ranurados. Los frentes de los cajones se pueden ajustar aflojando los tornillos, haciendo los ajustes necesarios y volviendo a apretar los tornillos.

Página 37

CARGA MAXIMA

Esta unidad ha sido diseñada para soportar la carga máxima anotada. El exceder estos límites puede causar inestabilidad, colapsarse y/o causar serias lesiones.

ADVERTENCIA: Riesgo de lesiones a las personas - no coloque un televisor sobre muebles. Este mueble no está aprobado para su uso con un televisor.

Página 38

Registre su producto para recibir lo siguiente:

- * Detalles de nuevas tendencias - Vistazo a lo nuevo
- * Encuestas - alee su voz entre su comunidad
- * Códigos de ofertas y descuentos exclusivos
- * Fácil y rápido servicio de partes de remplace

Para registrar su producto, visite ameriwoodhome.com

Clasificación de 5 estrellas

Visite el sitio web de su tienda local, califique su comprado y denos sus comentarios!

Nos gustaría enviar un gran "Agradecimiento" a todos nuestros clientes por tomarse el tiempo de ensamblar este producto de Ameriwood Home, y por darnos sus valiosos comentarios.

Gracias

Français

Couverture Avant

CE LIVRET D'INSTRUCTION CONTIENT DES INFORMATIONS **IMPORTANTES** SUR LA SÉCURITÉ. VEUILLEZ LIRE ET GARDER POUR UNE RÉFÉRENCE FUTURE

Ne retournez pas ce produit! Contactez notre équipe de service à la clientèle amicale d'abord pour obtenir de l'aide.

Appelez-nous: 1-800-489-3351 (sans frais) du Lundi au Vendredi de 9h à 17h Heure Centrale

Visitez: www.ameriwoodhome.com

ATTENTION

Le meuble peut basculer et causer des blessures graves ou la mort.

Ancrer le meuble à une planche murale dans le mur (si indiqué).

Ne laissez pas les enfants grimper sur le meuble.

Placez les articles lourds sur les étagères ou dans les tiroirs inférieurs.

Astuces Utiles (page 2)

-Ouvrez votre article dans la zone que vous prévoyez de le garder pour moins de levage lourd

-Identifier, trier et compter les pièces avant d'essayer d'assembler

-Les goujons de compression sont taraudés avec un Marteau

-Les glissières sont marquées d'un R (droit) et d'un L (gauche) pour un bon placement

-Assurez-vous toujours de faire face la pointe situé sur le haut de la Serrure de Came vers le bord extérieur

-Utiliser tous les clous fournis pour le panneau arrière et les répartir également

-Le panneau arrière doit être utilisé pour vous assurer que votre appareil est robuste

-N'utilisez pas de produits chimiques agressifs ou de nettoyeurs abrasifs sur cet appareil

-Ne jamais pousser, tirer, ou faire glisser votre meuble

Avant de Commencer (page 3)

-Lisez attentivement chaque étape et suivez le bon ordre

-Séparez et comptez toutes vos pièces et matériaux

-Donnez-vous suffisamment de place pour l'assemblage

-Avoir les outils suivants: tournevis à tête plate, #2 tournevis Phillips, et Marteau

-Attention: Si vous utilisez une perceuse électrique ou un tournevis électrique pour visser, veillez à ralentir et arrêter lorsque la vis est bien serrée. Le non-respect de cette consigne peut endommager la vis.

Système de Fixation de Came (page 3)

Ce Système de Fixation de Came sera utilisé tout au long de l'assemblage

Français

Page 9/10

Vous devrez taper sur le connecteur (7) avec un marteau pour l'insérer complètement. Assurez-vous que le connecteur est positionné comme illustré avant de le taper dans le trou.

Page 12/13

Tourner dans le sens des aiguilles d'une montre pour verrouiller en place.

Page 16

Ne serrez pas complètement la vis.

Page 18

Remarque : les chevilles en bois (3) s'insèrent dans l'extrémité comportant les plus grands trous.

Page 22

Fixez le haut (C) comme indiqué en vous assurant que les chevilles en bois (3) dans les deux dos (F) s'engagent dans les trous le long du bord arrière du haut.

Page 23

Remarque : les étapes 15 à 20 permettront d'assembler le tiroir supérieur. Vous utiliserez les petits côtés du tiroir, le dos du tiroir et les petits supports de tiroir (10).

Page 24

Veillez à ce que les rainures des côtés du tiroir soient centrées sur la rainure de l'avant du tiroir supérieur.

Page 26/32

Remarque : Vous devrez taper sur les fixations d'entraînement (4) avec un marteau pour les fixer solidement.

Page 27

Fixez d'abord les glissières, puis la poignée.

Page 33

Fixez d'abord les glissières, puis la poignée.

Page 35

Pour la maçonnerie, le béton ou d'autres matériaux muraux :

Consultez votre quincaillerie locale pour obtenir des ancrages appropriés afin de fixer solidement le support de sécurité.

IMPORTANT : CET APPAREIL DOIT ÊTRE FIXÉ AU MUR POUR ÉVITER TOUT BASCULEMENT. SUIVEZ CES INSTRUCTIONS POUR INSTALLER LE SUPPORT DE SÉCURITÉ ANTI-BASCULEMENT FOURNI AVEC CE PRODUIT.

Français

OPTION 1 : Fixation dans un montant de mur (méthode conseillée)

À l'aide d'un détecteur de montants, localisez un montant dans le mur. Placez votre appareil contre le mur, avec le support de sécurité aligné à cet endroit. Pour faciliter l'insertion de la vis, vous pouvez percer un trou pilote de 3 mm de diamètre à travers le support de sécurité dans le montant. Enfoncez la vis à travers le support de sécurité dans le montant du mur. Serrez la vis qui n'a pas été entièrement serrée à l'étape 8.

OPTION 2 : Fixation dans les cloisons sèches

Placez votre unité à l'endroit souhaité contre un mur et marquez le mur à travers le support de sécurité, puis mettez votre unité de côté. Percez un trou de 3/16 pouce de diamètre (5 mm) dans le panneau mural. Tapez sur l'ancrage mural dans le trou jusqu'à ce qu'il soit affleurant. Mettez votre appareil en place et fixez le support mural à l'ancrage mural à l'aide de la vis. Serrez la vis qui n'a pas été entièrement serrée à l'étape 8.

Page 36

Remarque : les trous des supports de tiroir sont fendus. Les façades des tiroirs peuvent être ajustées en desserrant les vis, en effectuant les ajustements nécessaires et en resserrant les vis.

Page 37

CHARGES MAXIMALES

Ce meuble a été conçu pour supporter les charges maximales indiquées. En excédant ces limites de charge, le meuble pourrait devenir instable, s'effondrer, et/ou causer des blessures graves.

AVERTISSEMENT : Risque de blessure corporelle - ne pas placer une télévision sur ce meuble. Ce meuble n'est pas approuvé pour une utilisation avec une télévision.

Page 38

Enregistrez votre produit pour recevoir les éléments suivantes:

- * Détails sur les nouvelles tendances - un aperçu sur les nouveautés
- * Sondages - avoir une voix au sein de notre communauté
- * Offres exclusives et codes promo
- * Service de pièces de rechange rapide et facile

Pour enregistrer votre produit, visitez ameriwoodhome.com

5 Étoiles

Visitez le site Web de votre détaillant local, évaluez votre produit acheté et laissez-nous quelques commentaires !

Nous tenons à offrir un grand "Merci" à tous nos clients pour avoir pris le temps d'assembler ce produit "Ameriwood Home", et de nous donner vos commentaires précieux.

Merci